

Answers to Odd-Numbered Problems, 3rd Edition of Games and Information, Rasmusen

September 11, 1999

This appendix contains answers to the odd-numbered problems in the book. The answers to the even-numbered problems are available to instructors or self-studiers on request to me at Erasmuse@indiana.edu.

Other books which contain exercises with answers include Bierman & Fernandez (1993), Binmore (1992), Fudenberg & Tirole (1991a), J. Hirshleifer & Riley (1992), and Moulin (1986). I must ask pardon of any authors from whom I have borrowed without attribution in the problems below; these are the descendants of problems that I wrote for teaching without careful attention to my sources.

PROBLEMS FOR CHAPTER 1

1.1: Nash and Iterated Dominance.

(1.1a) Show that every iterated dominance equilibrium s^* is Nash.

Answer. Suppose that s^* is not Nash. This means that there exists some i and s'_i such that i could profitably deviate, i.e., $\pi_i(s^*) \leq \pi_i(s'_i, s^*_{-i})$. But that means that once iterated deletion reached the point where the only strategies left for player i were s_i^* and s'_i , it could not be true that s_i^* strongly dominated s'_i . Therefore, iterated deletion could not possibly reach s^* .

(1.1b) Show by counterexample that not every Nash equilibrium can be generated by iterated dominance.

Answer. In “Ranked Coordination” (Table 1.7) no strategy can be eliminated by dominance, and the boldfaced strategies are Nash. (question 1.2c. This question should indeed be changed on p. 33 of the book.)

(1.1c) Is every iterated dominance equilibrium made up of strategies that are not weakly dominated?

Answer. No. Look at the “Battle of the Bismarck Sea” (Table 1.2). *North* is not weakly dominant for Kenney. A strategy that is in the equilibrium strategy profile might be a bad reply to some strategies that iterated deletion removed from the original game.

1.3: Pareto Dominance.¹

- (1.3a) If a strategy combination s^* is a dominant strategy equilibrium, does that mean it weakly pareto-dominates all other strategy combinations?

Answer. No— think of the “Prisoner’s Dilemma”, in Table 1.1. (*Confess, Confess*) is a dominant strategy equilibrium, but it does not weakly pareto-dominate (*Deny, Deny*)

- (1.3b) If a strategy combination s strongly pareto-dominates all other strategy combinations, does that mean it is a dominant strategy equilibrium?

Answer. No— think of “Ranked Coordination”, in Table 1.7. (*Large, Large*) strongly pareto-dominates all other strategy profiles, but is not a dominant strategy equilibrium.²

- (1.3c) If s weakly pareto-dominates all other strategy combinations, then must it be a Nash equilibrium?

Answer. Yes. If s is weakly pareto-dominant, then $\pi_i(s) \geq \pi_i(s'), \forall s', \forall i$. If s is Nash, $\pi_i(s) \geq \pi_i(s'_i, s_{-i}), \forall s'_i, \forall i$. Since $\{s'_i, s_{-i}\}$ is a subset of $\{s'\}$, if s satisfies the condition to be weakly pareto-dominant, it must also be a Nash equilibrium.

1.5: Drawing Outcome Matrices. It can be surprisingly difficult to look at a game using new notation. In this exercise, redraw the outcome matrix in a different form than in the main text. In each case, read the description of the game and draw the outcome matrix as instructed. You

¹This question is based on notes by Jong-shin Wei.

²The “Prisoner’s Dilemma” is not a good example for this problem, because (*Deny, Deny*) does not pareto-dominate (*Deny, Confess*).

will learn more if you do this from the description, without looking at the conventional outcome matrix.

- (1.5a) The Battle of the Sexes (Table 1.8). Put (*Prize Fight*, *Prize Fight*) in the northwest corner, but make the woman the row player.

Answer. See Table C.1.

Table C.1 “Rearranged Battle of the Sexes I”

		Man		
		<i>Prize Fight</i>		<i>Ballet</i>
Woman:	<i>Prize Fight</i>	1,2	←	-5,-5
		↑		↓
	<i>Ballet</i>	-1,-1	→	2,1

Payoffs to: (Woman, Man).

- (1.5b) The Prisoner’s Dilemma (Table 1.2). Put (*Confess*, *Confess*) in the northwest corner.

Answer. See Table C.2.

Table C.2 “Rearranged Prisoner’s Dilemma”

		Column	
		<i>Confess</i>	<i>Deny</i>
Row:	<i>Confess</i>	-8,-8	← 0,-10
		↑	↑
	<i>Deny</i>	-10,0	← -1,-1

Payoffs to: (Row, Column).

- (1.5c) The Battle of the Sexes (Table 1.8). Make the man the row player, but put (*Ballet*, *Prize Fight*) in the northwest corner.

Answer. See Table C.3.

Table C.3 “Rearranged Battle of the Sexes II”

		Woman	
		<i>Prize Fight</i>	<i>Ballet</i>
	<i>Ballet</i>	-5,-5	→ 1,2
Man:		↓	↑
	<i>Prize Fight</i>	2,1	← -1,-1

Payoffs to: (Man, Woman).

PROBLEMS FOR CHAPTER 2

2.1: The Monty Hall Problem. You are a contestant on the TV show, “Let’s Make a Deal.” You face three curtains, labelled A, B and C. Behind two of them are toasters, and behind the third is a Mazda Miata car. You choose A, and the TV showmaster says, pulling curtain B aside to reveal a toaster, “You’re lucky you didn’t choose B, but before I show you what is behind the other two curtains, would you like to change from curtain A to curtain C?” Should you switch? What is the exact probability that curtain C hides the Miata?

Answer. You should switch to curtain C, because

$$\begin{aligned}
 \text{Prob (Miata behind C | Host chose B)} &= \frac{\text{Prob(Host chose B | Miata behind C)Prob(Miata behind C)}}{\text{Prob(Host chose B)}} \\
 &= \frac{(1)(\frac{1}{3})}{(1)(\frac{1}{3})+(\frac{1}{2})(\frac{1}{3})} \\
 &= \frac{2}{3}.
 \end{aligned}$$

The key is to remember that this is a game. The host’s action has revealed more than that the Miata is not behind B; it has also revealed that the host did not want to choose curtain C. If the Miata were behind B or C, he would pull aside the curtain it was not behind. Otherwise, he would pull aside a curtain randomly. His choice tells you nothing new about the probability that the Miata is behind curtain A, which remains $\frac{1}{3}$, so the probability of it being behind C must rise to $\frac{2}{3}$ (to make the total probability equal one).

2.3: Cancer Tests. Imagine that you are being tested for cancer, using a test that is 98% accurate. If you indeed have cancer, the test shows positive (indicating cancer) 98% of the time. If you do not have cancer, it shows negative 98% of the time. You have heard that 1 in 20 people in the population actually have cancer. Now your doctor tells you that you tested positive, but you shouldn't worry because his last 19 patients all died. How worried should you be? What is the probability you have cancer?

Answer. Doctors, of course, are not mathematicians. Using Bayes' Rule:

$$\begin{aligned} \text{Prob}(\text{Cancer}|\text{Positive}) &= \frac{\text{Prob}(\text{Positive}|\text{Cancer})\text{Prob}(\text{Cancer})}{\text{Prob}(\text{Positive})} \\ &= \frac{0.98(0.05)}{0.98(0.05)+0.02(0.95)} \quad (1) \\ &\approx 0.72. \end{aligned}$$

With a 72 percent chance of cancer, you should be very worried. But at least it is not 98 percent.

Here is another way to see the answer. Suppose 10,000 tests are done. Of these, an average of 500 people have cancer. Of these, 98% test positive on average—490 people. Of the 9,500 cancer-free people, 2% test positive on average—190 people. Thus there are 680 positive tests, of which 490 are true positives. The probability of having cancer if you test positive is 490/680, about 72%.

2.5: Joint Ventures. Software Inc. and Hardware Inc. have formed a joint venture. Each can exert either high or low effort, which is equivalent to costs of 20 and 0. Hardware moves first, but Software cannot observe his effort. Revenues are split equally at the end, and the two firms are risk neutral. If both firms exert low effort, total revenues are 100. If the parts are defective, the total revenue is 100; otherwise, if both exert high effort, revenue is 200, but if only one player does, revenue is 100 with probability 0.9 and 200 with probability 0.1. Before they start, both players believe that the probability of defective parts is 0.7. Hardware discovers the truth about the parts by observation before he chooses effort, but Software does not.

- (2.5a) Draw the extensive form and put dotted lines around the information sets of Software at any nodes at which he moves.

Answer. See Figure A.1.

Figure A.1 The Extensive Form for the Joint Ventures Game

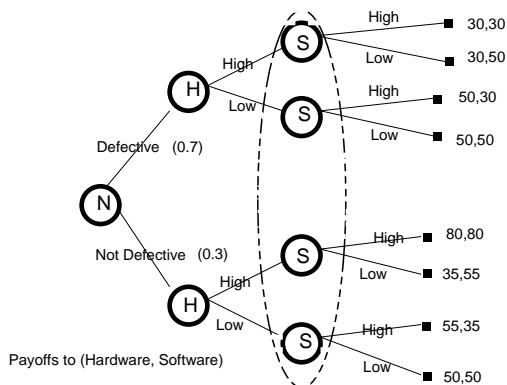

Figure A1.1 The Extensive Form for the Joint Ventures Game

(2.5b) What is the Nash equilibrium?

Answer. (*Low* if defective parts, *Low* if not defective parts, *Low*).

(2.5c) What is Software's belief, in equilibrium, as to the probability that Hardware chooses low effort?

Answer. One. In equilibrium, Hardware always chooses *Low*.

(2.5d) If Software sees that revenue is 100, what probability does he assign to defective parts if he himself exerted high effort and he believes that Hardware chose low effort?

Answer. $0.72 (= (1)(0.7)/[(1)(0.7)+(0.9)(0.3)])$.

PROBLEMS FOR CHAPTER 3

3.1: Presidential Primaries. Smith and Jones are fighting it out for the Democratic nomination for President of the United States. The more months

they keep fighting, the more money they spend, because a candidate must spend one million dollars a month in order to stay in the race. If one of them drops out, the other one wins the nomination, which is worth 11 million dollars. The discount rate is r per month. To simplify the problem, you may assume that this battle could go on forever if neither of them drops out. Let θ denote the probability that an individual player will drop out each month in the mixed-strategy equilibrium.

- (3.1a) In the mixed-strategy equilibrium, what is the probability θ each month that Smith will drop out? What happens if r changes from 0.1 to 0.15?

Answer. The value of exiting is zero. The value of staying in is $V = \theta(10) + (1 - \theta)(-1 + V/(1 + r))$. Thus, $V - (1 - \theta)V/(1 + r) = 10\theta - 1 + \theta$, and $V = (11\theta - 1)(1 + r)/(r + \theta)$. Thus, $\theta = 1/11$ in equilibrium.

The discount rate does not affect the equilibrium outcome, so a change in r produces no observable effect.

- (3.1b) What are the two pure-strategy equilibria?

Answer. (Smith drops out, Jones stays in no matter what) and (Jones drops out, Smith stays in no matter what).

- (3.1c) If the game only lasts one period, and the Republican wins the general election (for Democrat payoffs of zero) if both Democrats refuse to exit, what is the probability γ with which each candidate exits in a symmetric equilibrium?

Answer. The payoff matrix is shown in Table A.5.

Table A.5 Fighting Democrats

		Jones	
		<i>Exit</i> (γ)	<i>Stay</i> ($1 - \gamma$)
Smith	<i>Exit</i> (γ)	0,0	0, 10
	<i>Stay</i> ($1 - \gamma$)	10,0	-1,-1

The value of exiting is $V(\textit{exit}) = 0$. The value of staying in is $V(\textit{Stay}) = 10\gamma + (-1)(1 - \gamma) = 11\gamma - 1$. Hence, each player stays in with probability $\gamma = 1/11$ — the same as in the war of attrition of part (a).

3.3: Uniqueness in Matching Pennies. In the game Matching Pennies, Smith and Jones each show a penny with either heads or tails up. If they choose the same side of the penny, Smith gets both pennies; otherwise, Jones gets them.

1. (3.3a)] Draw the outcome matrix for Matching Pennies.

Table A.6 “Matching Pennies”

		Jones	
		<i>Heads</i> (θ)	<i>Tails</i> ($1 - \theta$)
Smith:	<i>Heads</i> (γ)	1, -1	-1, 1
	<i>Tails</i> ($1 - \gamma$)	-1, 1	1, -1

Payoffs to: (Smith, Jones).

- (3.3b) Show that there is no Nash equilibrium in pure strategies.

Answer. (*Heads, Heads*) is not Nash, because Jones would deviate to *Tails*. (*Heads, Tails*) is not Nash, because Smith would deviate to *Tails*. (*Tails, Tails*) is not Nash, because Jones would deviate to *Heads*. (*Tails, Heads*) is not Nash, because Smith would deviate to *Heads*.

- (3.3c) Find the mixed-strategy equilibrium, denoting Smith’s probability of *Heads* by γ and Jones’ by θ .

Answer. Equate the pure strategy payoffs. Then for Smith, $\pi(\textit{Heads}) = \pi(\textit{Tails})$, and

$$\theta(1) + (1 - \theta)(-1) = \theta(-1) + (1 - \theta)(1), \quad (2)$$

which tells us that $2\theta - 1 = -2\theta + 1$, and $\theta = 0.5$. For Jones, $\pi(\textit{Heads}) = \pi(\textit{Tails})$, so

$$\gamma(-1) + (1 - \gamma)(1) = \gamma(1) + (1 - \gamma)(-1), \quad (3)$$

which tells us that $1 - 2\gamma = 2\gamma - 1$ and $\gamma = 0.5$.

(3.3d) Prove that there is only one mixed-strategy equilibrium.

Answer. Suppose $\theta > 0.5$. Then Smith will choose *Heads* as a pure strategy. Suppose $\theta < 0.5$. Then Smith will choose *Tails* as a pure strategy. Similarly, if $\gamma > 0.5$, Jones will choose *Tails* as a pure strategy, and if $\gamma < 0.5$, Jones will choose *Heads* as a pure strategy. This leaves $(0.5, 0.5)$ as the only possible mixed-strategy equilibrium.

Compare this with the multiple equilibria in problem 3.5. In that problem, there are three players, not two. Should that make a difference?

3.5: A Voting Paradox. Adam, Charles, and Vladimir are the only three voters in Podunk. Only Adam owns property. There is a proposition on the ballot to tax property-holders 120 dollars and distribute the proceeds equally among all citizens who do not own property. Each citizen dislikes having to go to the polling place and vote (despite the short lines), and would pay 20 dollars to avoid voting. They all must decide whether to vote before going to work. The proposition fails if the vote is tied. Assume that in equilibrium Adam votes with probability θ and Charles and Vladimir each vote with the same probability γ , but they decide to vote independently of each other.

(3.5a) What is the probability that the proposition will pass, as a function of θ and γ ?

Answer. The probability that Adam loses can be decomposed into three probabilities— that all three vote, that Adam does not vote but one other does, and that Adam does not vote but both others do. These sum to $\theta\gamma^2 + (1 - \theta)2\gamma(1 - \gamma) + (1 - \theta)\gamma^2$, which is, rearranged, $\gamma(2\gamma\theta - 2\theta + 2 - \gamma)$.

(3.5b) What are the two possible equilibrium probabilities γ_1 and γ_2 with which Charles might vote? Why, intuitively, are there two symmetric equilibria?

Answer. The equilibrium is in mixed strategies, so each player must have equal payoffs from his pure strategies. Let us start with Adam's payoffs. If he votes, he loses 20 immediately, and 120 more if both Charles and Vladimir have voted.

$$\pi_a(\textit{Vote}) = -20 + \gamma^2(-120). \quad (4)$$

If Adam does not vote, then he loses 120 if either Charles or Vladimir vote, or if both vote:

$$\pi_a(\text{Not Vote}) = (2\gamma(1 - \gamma) + \gamma^2)(-120) \quad (5)$$

Equating $\pi_a(\text{Vote})$ and $\pi_a(\text{Not Vote})$ gives

$$0 = 20 - 240\gamma + 240\gamma^2. \quad (6)$$

The quadratic formula solves for γ :

$$\gamma = \frac{12 \pm \sqrt{144 - 4 \cdot 1 \cdot 12}}{24}. \quad (7)$$

This equations has two solutions, $\gamma_1 = 0.09$ (rounded) and $\gamma_2 = 0.91$ (rounded).

Why are there two solutions? If Charles and Vladimir are sure not to vote, Adam will not vote, because if he does not vote he will win, 0-0. If Charles and Vladimir are sure to vote, Adam will not vote, because if he does not vote he will lose, 2-0, but if he does vote, he will lose anyway, 2-1. Adam only wants to vote if Charles and Vladimir vote with moderate probabilities. Thus, for him to be indifferent between voting and not voting, it suffices either for γ to be low or to be high—it just cannot be moderate.

- (3.5c) What is the probability θ that Adam will vote in each of the two symmetric equilibria?

Answer. Now use the payoffs for Charles, which depend on whether Adam and Vladimir vote.

$$\pi_c(\text{Vote}) = -20 + 60[\gamma + (1 - \gamma)(1 - \theta)] \quad (8)$$

$$\pi_c(\text{Not Vote}) = 60\gamma(1 - \theta). \quad (9)$$

Equating these and using $\gamma^* = 0.09$ gives $\theta = 0.70$ (rounded). Equating these and using $\gamma^* = 0.91$ gives $\theta = 0.30$ (rounded).

- (3.5d) What is the probability that the proposition will pass?

Answer. The probability that Adam will lose his property is, using the equation in part (a) and the values already discovered, either 0.06 (rounded) ($= (0.7)(0.09)^2 + (0.3)(2(0.09)(0.91) + (0.09)^2)$) or 0.37 (rounded ($= (0.3)(0.91)^2 + (0.7)(2(0.91)(0.09) + (0.91)^2)$)).

PROBLEMS FOR CHAPTER 4

4.1: Repeated Entry Deterrence. Consider two repetitions without discounting of the game Entry Deterrence I from Section 4.2. Assume that there is one entrant, who sequentially decides whether to enter two markets that have the same incumbent.

(4.1a) Draw the extensive form of this game.

Answer. See Figure A.2. If the entrant does not enter, the incumbent's response to entry in that period is unimportant.

Figure A.2 “Repeated Entry Deterrence”

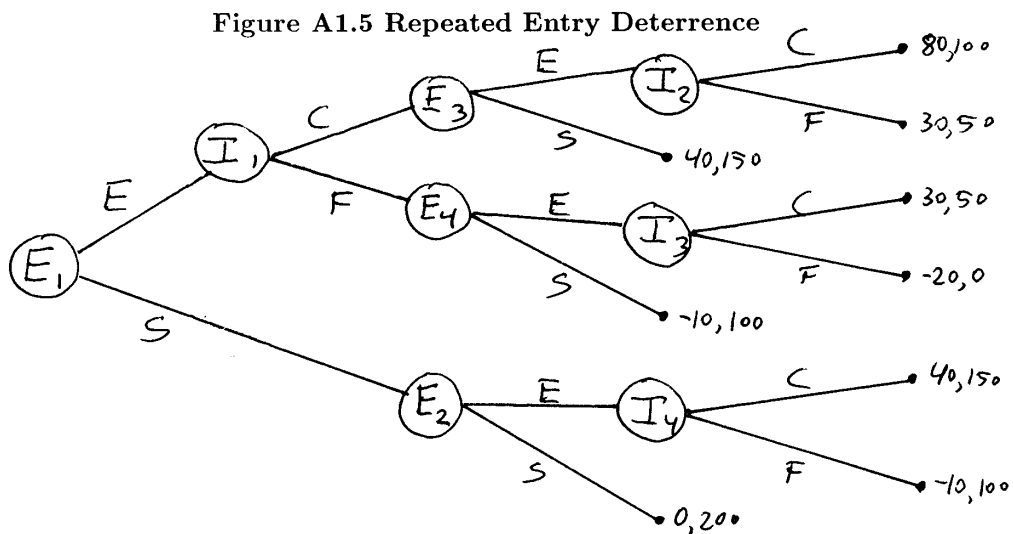

(4.1b) What are the 16 elements of the strategy sets of the entrant?

Answer. The entrant makes a binary decision at four nodes, so his strategy must have four components, strictly speaking, and the number of possible arrangements is $(2)(2)(2)(2) = 16$. Table A.7 shows the strategy space, with E for *Enter* and S for *Stay out*.

Table A.7 The Entrant's Strategy Set

Strategy	E_1	E_2	E_3	E_4
1	E	E	E	E
2	E	E	E	E
3	E	E	E	S
4	E	E	S	S
5	E	S	S	S
6	E	S	E	E
7	E	S	S	E
8	E	S	E	S
9	S	E	E	E
10	S	S	E	E
11	S	S	S	E
12	S	S	S	S
13	S	E	S	S
14	S	E	S	E
15	S	E	E	S
16	S	S	E	S

Usually modellers are not so careful. Table A.7 includes action rules for the Entrant to follow at nodes that cannot be reached unless the Entrant trembles, somehow deviating from its own strategy. If the Entrant chooses Strategy 16, for example, nodes E_3 and E_4 cannot possibly be reached, even if the Incumbent deviates, so one might think that the parts of the strategy dealing with those nodes are unimportant. Table A.8 removes the unimportant parts of the strategy, and Table A.16 condenses the strategy set down to its six importantly distinct strategies.

Table A.8 The Entrant's Strategy Set, Abridged Version I

Strategy	E_1	E_2	E_3	E_4
1	E	-	E	E
2	E	-	E	E
3	E	-	E	S
4	E	-	S	S
5	E	-	S	S
6	E	-	E	E
7	E	-	S	E
8	E	-	E	S
9	S	E	-	-
10	S	S	-	-
11	S	S	-	-
12	S	S	-	-
13	S	E	-	-
14	S	E	-	-
15	S	E	-	-
16	S	S	-	-

Table A.9 The Entrant's Strategy Set, Abridged Version II

Strategy	E_1	E_2	E_3	E_4
1	E	-	E	E
3	E	-	E	S
4	E	-	S	S
7	E	-	S	E
9	S	E	-	-
10	S	S	-	-

(4.1c) What is the subgame perfect equilibrium?

Answer. The entrant always enters and the incumbent always colludes.

(4.1d) What is one of the nonperfect Nash equilibria?

Answer. The entrant stays out in the first period, and enters in the second period. The incumbent fights any entry that might occur in the first period, and colludes in the second period.

4.3: Heresthetics in Pliny and the Freedmens' Trial. (Pliny, 1963, pp. 221-4, Riker, 1986, pp.78-88). Afranius Dexter died mysteriously, perhaps dead by his own hand, perhaps killed by his freedmen (servants a step above slaves), or perhaps killed by his freedmen by his own orders. The freedmen went on trial before the Roman Senate. Assume that 45 percent of the senators favor acquittal, 35 percent favor banishment, and 20 percent favor execution, and that the preference rankings in the three groups are $A \succ B \succ E$, $B \succ A \succ E$, and $E \succ B \succ A$. Also assume that each group has a leader and votes as a bloc.

- (4.3a) Modern legal procedure requires the court to decide guilt first and then assign a penalty if the accused is found guilty. Draw a tree to represent the sequence of events (this will not be a game tree, since it will represent the actions of groups of players, not of individuals). What is the outcome in a perfect equilibrium?

Answer. Guilt would win in the first round by a vote of 55 to 45, and banishment would win in the second by 80 to 20. See Figure A.3.

Figure A.3 Modern Legal Procedure

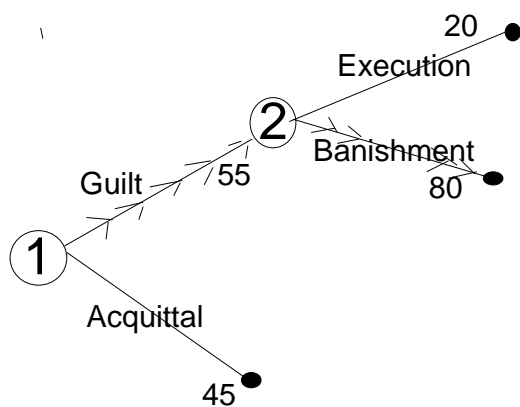

Modern Legal Procedure

- (4.3b) Suppose that the acquittal bloc can pre-commit to how they will vote in the second round if guilt wins in the first round. What will they do, and what will happen? What would the execution bloc do if they could control the second-period vote of the acquittal bloc?

Answer. The acquittal bloc would commit to execution, inducing the Banishment bloc to vote for Acquittal in the first round, and acquittal would win. The execution bloc would order the acquittal bloc to choose banishment in the second round to avoid making the banishment bloc switch to acquittal.³

- (4.3c) The normal Roman procedure began with a vote on execution versus no execution, and then voted on the alternatives in a second round if execution failed to gain a majority. Draw a tree to represent this. What would happen in this case?

Answer. Execution would fail by a vote of 20 to 80, and banishment would then win by 55 to 45. See Figure A.4.

Figure A.4 Roman Legal Procedure

³Note that preferences do not always work out this way. In Athens, six centuries before the Pliny episode, Socrates was found guilty in a first round of voting and then sentenced to death (instead of a lesser punishment like banishment) by a bigger margin in the second round. This would imply the ranking of the acquittal bloc there was AEB, except for the complicating factor that Socrates was a bit insulting in his sentencing speech.

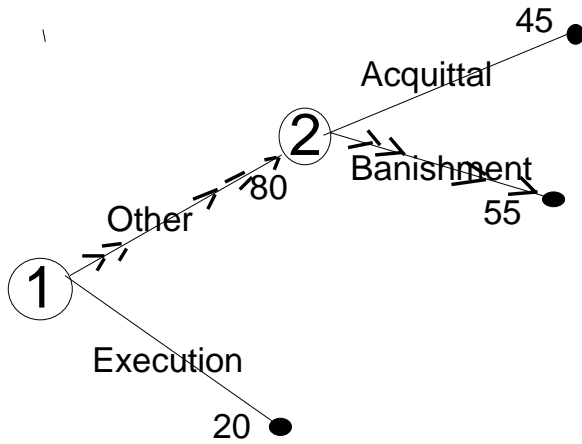

Roman Legal Procedure

- (4.3d) Pliny proposed that the Senators divide into three groups, depending on whether they supported acquittal, banishment, or execution, and that the outcome with the most votes should win. This proposal caused a roar of protest. Why did he propose it?

Answer. It must be that Pliny favored acquittal and hoped that every senator would vote for his preference. Acquittal would then win 45 to 35 to 25.

- (4.3e) Pliny did not get the result he wanted with his voting procedure. Why not?

Answer. Pliny said that his arguments were so convincing that the senator who made the motion for the death penalty changed his mind, along with his supporters, and voted for banishment, which won (by 55 to 45 in our hypothesized numbers). He forgot that people do not always vote for their first preference. The execution bloc saw that acquittal would win unless they switched to banishment.

- (4.3f) Suppose that personal considerations made it most important to a senator that he show his stand by his vote, even if he had to sacrifice his preference for a particular outcome. If there were a vote over whether to

use the traditional Roman procedure or Pliny's procedure, who would vote with Pliny, and what would happen to the freedmen?

Answer. Traditional procedure would win by capturing the votes of the execution bloc and the banishment bloc, and the freedmen would be banished. In this case, the voting procedure would matter to the result, because each senator would vote for his preference.

PROBLEMS FOR CHAPTER 5 Reputation and Repeated Games

5.1: Overlapping Generations. ⁴ There is a long sequence of players. One player is born in each period t , and he lives for periods t and $t+1$. Thus, two players are alive in any one period, a youngster and an oldster. Each player is born with one unit of chocolate, which cannot be stored. Utility is increasing in chocolate consumption, and a player is very unhappy if he consumes less than 0.3 units of chocolate in a period: the per-period utility functions are $U(C) = -1$ for $C < 0.3$ and $U(C) = C$ for $C \geq 0.3$, where C is consumption. Players can give away their chocolate, but, since chocolate is the only good, they cannot sell it. A player's action is to consume X units of chocolate as a youngster and give away $1 - X$ to some oldster. Every person's actions in the previous period are common knowledge, and so can be used to condition strategies upon.

(5.1a) If there is finite number of generations, what is the unique Nash equilibrium?

Answer. $X=1$. The Chainstore Paradox applies. Youngster T , the last one, has no incentive to give anything to Oldster $T-1$. Therefore, Youngster $T-1$ has no incentive either, and so for every t .

(5.1b) If there are an infinite number of generations, what are two Pareto-ranked perfect equilibria?

Answer. (i) ($X = 1$, regardless of what others do), and (ii) ($X = 0.5$, unless some player has deviated, in which case $X = 1$). Equilibrium (ii) is pareto superior.

⁴See Samuelson (1958).

- (5.1c) If there is a probability θ at the end of each period (after consumption takes place) that barbarians will invade and steal all the chocolate (leaving the civilized people with payoffs of -1 for any X), what is the highest value of θ that still allows for an equilibrium with $X = 0.5$?

Answer. The payoff from the equilibrium strategy is $0.5 + (1 - \theta)0.5 + \theta(-1) = 1 - 1.5\theta$. The payoff from deviating to $X = 1$ is $1 - 1 = 0$. These are equal if $1 - 1.5\theta = 0$; that is, if $\theta = \frac{2}{3}$. Hence, θ can take values up to $\frac{2}{3}$ and the $X = 0.5$ equilibrium can still be maintained.

5.3: Repeated Games.⁵ Players Benoit and Krishna repeat the game in Table 5.7 three times, with discounting:

Table 5.7 A Benoit-Krishna Game

		Krishna		
		<i>Deny</i>	<i>Waffle</i>	<i>Confess</i>
Benoit:	<i>Deny</i>	10,10	-1, -12	-1, 15
	<i>Waffle</i>	-12, -1	8,8	-1, -1
	<i>Confess</i>	15, -1	8, -1	0, 0

Payoffs to: (Benoit, Krishna).

- (5.3a) Why is there no equilibrium in which the players play *Deny* in all three periods?
- (5.3b) Describe a perfect equilibrium in which both players pick *Deny* in the first two periods.
- (5.3c) Adapt your equilibrium to the twice-repeated game.
- (5.3d) Adapt your equilibrium to the T -repeated game.

⁵See Benoit & Krishna (1985).

- (5.3e) What is the greatest discount rate for which your equilibrium still works in the 3-period game?

5.5: The Repeated Prisoner's Dilemma. Set $P = 0$ in the general Prisoner's Dilemma in Table 1.9, and assume that $2R > S + T$.

- (5.5a) Show that the Grim Strategy, when played by both players, is a perfect equilibrium for the infinitely repeated game. What is the maximum discount rate for which the Grim Strategy remains an equilibrium?

Answer. The grim strategy is a perfect equilibrium because the payoff from continued cooperation is $R + \frac{R}{r}$, which for low discount rates is greater than the payoff from $(Confess, Deny)$ once and $(Confess, Confess)$ forever after, which is $T + \frac{0}{r}$. To find the maximum discount rate, equate these two payoffs: $R + \frac{R}{r} = T$. This means that $r = \frac{T-R}{R}$ is the maximum.

- (5.5b) Show that Tit-for-Tat is not a perfect equilibrium in the infinitely repeated Prisoner's Dilemma with no discounting.

Answer. Suppose Row has played *Confess*. Will Column retaliate? If both follow tit-for-tat after the deviation, retaliation results in a cycle of $(Confess, Deny)$, $(Deny, Confess)$, forever. Row's payoff is $T + S + T + S + \dots$. If Column forgives, and they go back to cooperating, on the other hand, his payoff is $R + R + R + R + \dots$. Comparing the first four periods, forgiveness has the higher payoff because $4R > 2S + 2T$. The payoffs of the first four periods simply repeat an infinite number of times to give the total payoff, so forgiveness dominates retaliation, and tit-for-tat is not perfect.⁶

5.7: Grab the Dollar. Table 5.10 shows the payoffs for the simultaneous-move game of Grab the Dollar. A silver dollar is put on the table between Smith and Jones. If one grabs it, he keeps the dollar, for a payoff of 4 utils. If both grab, then neither gets the dollar, and both feel bitter. If neither grabs, each gets to keep something.

⁶See Kalai, Samet and Stanford (1988).

Table 5.9 Grab the Dollar

		Jones	
		<i>Grab</i> (θ)	<i>Wait</i> ($1 - \theta$)
Smith:	<i>Grab</i> (θ)	-1, -1	4, 0
	<i>Wait</i> ($1 - \theta$)	0, 4	1, 1

Payoffs to: (Smith, Jones).

(5.7a) What are the evolutionarily stable strategies?

Answer. The ESS is mixed and unique. Let $Prob(Grab) = \theta$. Then $\pi(Grab) = -1(\theta) + 4(1 - \theta) = \pi(Wait) = 0(\theta) + 1(1 - \theta)$, which solves to $\theta = 3/4$. Three fourths of the population plays *Grab*.

(5.7b) Suppose each player in the population is a point on a continuum, and that the initial amount of players is 1, evenly divided between *Grab* and *Wait*. Let $N_t(s)$ be the amount of players playing a particular strategy in period t and let $\pi_t(s)$ be the payoff. Let the population dynamics be $N_{t+1}(i) = (2N_t(i)) \left(\frac{\pi_t(i)}{\sum_j \pi_t(j)} \right)$. Find the missing entries in Table 5.11.

Table 5.11 Grab the Dollar: Dynamics

t	$N_t(G)$	$N_t(W)$	$N_t(total)$	θ	$\pi_t(G)$	$\pi_t(w)$
0	0.5	0.5	1	0.5	1.5	0.5
1						
2						

Answer. See Table C.7.

Table C.7 “Grab the Dollar”: Dynamics I

t	$N_t(G)$	$N_t(W)$	$N_t(total)$	θ	$\pi_t(G)$	$\pi_t(w)$
0	0.5	0.5	1	0.5	1.5	0.5
1	0.75	0.25	1	0.75	0.25	0.25
2	0.75	0.25	1	0.75	0.25	0.25

(5.7c) Repeat part (b), but with the dynamics $N_{t+t}(s) = [1 + \frac{\pi_t(s)}{\sum_j \pi_t(j)}][2N_t(s)]$.

Answer. See Table C.8.

Table C.8 “Grab the Dollar”: Dynamics II

t	$N_t(G)$	$N_t(W)$	$N_t(total)$	θ	$\pi_t(G)$	$\pi_t(w)$
0	.5	0.5	1	.5	1.5	0.5
1	1.75	1.25	3	0.58	1.1	0.42
2	6.03	3.19	9.22	0.65	0.75	0.35

(5.7d) Which three games that have appeared so far in the book resemble *Grab the Dollar*?

Answer. “Chicken”, “The Battle of the Sexes”, and “The Hawk-Dove Game”.

PROBLEMS FOR CHAPTER 6 Dynamic Games with Asymmetric Information

6.1: Cournot Duopoly Under Incomplete Information about Costs.

This problem introduces incomplete information into the Cournot model of Chapter 3 and allows for a continuum of player types.

(6.1a) Modify the Cournot Game of Chapter 3 by specifying that Apex’ average cost of production is c per unit, while Brydox’ remains zero. What are the outputs of each firm if the costs are common knowledge? What are the numerical values if $c = 10$?

Answer. The payoff functions are

$$\begin{aligned}\pi_{Apex} &= (120 - q_a - q_b - c)q_a \\ \pi_{Brydox} &= (120 - q_a - q_b - c)q_b\end{aligned}\tag{10}$$

The first order conditions are then

$$\begin{aligned}\frac{\partial \pi_{Apex}}{\partial q_a} &= 120 - 2q_a - q_b - c = 0 \\ \frac{\partial \pi_{Brydox}}{\partial q_b} &= 120 - q_a - 2q_b = 0\end{aligned}\tag{11}$$

Solving the first order conditions together gives

$$\begin{aligned} q_a &= 40 - \frac{2c}{3} \\ q_b &= 40 + \frac{c}{3} \end{aligned} \tag{12}$$

If $c = 10$, Apex produces $33 \frac{1}{3}$ and Brydox produces $43 \frac{1}{3}$. Apex's higher costs make it cut back its output, which encourages Brydox to produce more.

- (6.1b) Let Apex' cost c be c_{max} with probability θ and 0 with probability $1 - \theta$, so Apex is one of two types. Brydox does not know Apex' type. What are the outputs of each firm?

Answer. Apex's payoff function is the same as in part (a), because

$$\pi_{Apex} = (120 - q_a - q_b - c)q_a, \tag{13}$$

which yields the reaction function

$$q_a = 60 - \frac{q_b + c}{2}. \tag{14}$$

Brydox's expected payoff is

$$\pi_{Brydox} = (1 - \theta)(120 - q_a(c = 0) - q_b)q_b + \theta(120 - q_a(c = c_{max}) - q_b)q_b. \tag{15}$$

The first order condition is

$$\frac{\partial \pi_{Brydox}}{\partial q_b} = (1 - \theta)(120 - q_a(c = 0) - 2q_b) + \theta(120 - q_a(c = c_{max}) - 2q_b) = 0. \tag{16}$$

Now substitute the reaction function of Apex, equation (14), into (16) and condense a few terms to obtain

$$120 - 2q_b - [1 - \theta][60 - \frac{q_b + 0}{2}] - \theta[60 - \frac{q_b + c_{max}}{2}] = 0. \tag{17}$$

Solving for q_b yields

$$q_b = 40 + \frac{\theta c_{max}}{3} \tag{18}$$

One can then use equations (14) and (18) to find

$$q_a = 40 - \frac{\theta c_{max}}{6} - \frac{c}{2}. \quad (19)$$

Note that the outputs do not depend on θ or c_{max} separately, only on the expected value of Apex's cost, θc_{max} .

- (6.1c) Let Apex' cost c be drawn from the interval $[0, c_{max}]$ using the uniform distribution, so there is a continuum of types. Brydox does not know Apex' type. What are the outputs of each firm?

Answer. Apex's payoff function is the same as in parts (a) and (b),

$$\pi_{Apex} = (120 - q_a - q_b - c)q_a, \quad (20)$$

which yields the reaction function

$$q_a = 60 - \frac{q_b + c}{2}. \quad (21)$$

Brydox's expected payoff is (letting the density of possible values of c be $f(c)$)

$$\pi_{Brydox} = \int_0^{c_{max}} (120 - q_a(c) - q_b)q_b f(c) dc. \quad (22)$$

The probability density is uniform, so $f(c) = \frac{1}{c_{max}}$. Substituting this into (22), the first order condition is

$$\frac{\partial \pi_{Brydox}}{\partial q_b} = \int_0^{c_{max}} (120 - q_a(c) - 2q_b) \left(\frac{1}{c_{max}} \right) dc = 0. \quad (23)$$

Now substitute in the reaction function of Apex, equation (21), which gives

$$\int_0^{c_{max}} (120 - [60 - \frac{q_b + c}{2}] - 2q_b) \left(\frac{1}{c_{max}} \right) dc = 0. \quad (24)$$

Simplifying by integrating out the terms in (24) which depend on c only through the probability density yields

$$60 - \frac{3q_b}{2} + \int_0^{c_{max}} \left(\frac{c}{2c_{max}} \right) dc = 0. \quad (25)$$

Integrating and rearranging yields

$$q_b = 40 + \frac{c_{max}}{6} \quad (26)$$

One can then use equations (21) and (26) to find

$$q_a = 40 - \frac{c_{max}}{12} - \frac{c}{2}. \quad (27)$$

- (6.1d) Outputs were 40 for each firm in the zero-cost game in Chapter 3. Check your answers in parts (b) and (c) by seeing what happens if $c_{max} = 0$.

Answer. If $c_{max} = 0$, then in part (b), $q_a = 40 - \frac{0}{6} - \frac{0}{2} = 40$ and $q_b = 40 + \frac{0}{3} = 40$, which is as it should be.

If $c_{max} = 0$, then in part (c), $q_a = 40 - \frac{0}{12} - \frac{0}{2} = 40$ and $q_b = 40 + \frac{0}{6} = 40$, which is as it should be.

- (6.1e) Let $c_{max} = 20$ and $\theta = 0.5$, so the expectation of Apex' average cost is 10 in parts (a), (b), and (c). What are the average outputs for Apex in each case?

Answer. In part (a), under full information, the outputs were $q_a = 33 \frac{1}{3}$ and $q_b = 43 \frac{1}{3}$. In part (b), with two types, $q_b = 43 \frac{1}{3}$ from equation (18), and the average value of q_a is

$$Eq_a = (1 - \theta) \left(40 - \frac{0.5(20)}{6} - \frac{0}{2} \right) + \theta \left(40 - \frac{0.5(20)}{6} - \frac{20}{2} \right) = 33 \frac{1}{3}. \quad (28)$$

In part (c), with a continuum of types, $q_b = 43 \frac{1}{3}$ and q_a is found from

$$\begin{aligned} Eq_a &= \int_0^{c_{max}} \left(40 - \frac{c_{max}}{8} - \frac{c}{2} \right) \left(\frac{1}{c_{max}} \right) dc \\ &= 40 - \frac{20}{8} - \frac{c_{max}^2}{4c_{max}} = 33 \frac{1}{3}. \end{aligned} \quad (29)$$

- (6.1f) Modify the model of part (b) so that $c_{max} = 20$ and $\theta = 0.5$, but somehow $c = 30$. What outputs do your formulas from part (b) generate? Is there anything this could sensibly model?

Answer. The purpose of Nature's move is to represent Brydox's beliefs about Apex, not necessarily to represent reality. Here, Brydox believes

that Apex's costs are either 0 or 20 but he is wrong and they are actually 30. In this game that does not cause problems for the analysis. Using equations (18) and (19), the outputs are $q_b = 43 \frac{1}{3}$ ($= 40 + \frac{0.5(20)}{3}$) and $q_a = 26 \frac{2}{3}$ ($= 40 - \frac{0.5(20)}{6} - \frac{30}{2}$).

If the game were dynamic, however, a problem would arise. When Brydax observes the first-period output of $q_a = 24 \frac{1}{6}$, what is he to believe about Apex's costs? Should he deduce that $c = 30$, or increase his belief that $c = 20$, or believe something else entirely? This departs from standard modelling.

6.3: Symmetric Information and Prior Beliefs. In the *Expensive-Talk Game* of Table 6.1, the *Battle of the Sexes* is preceded by a communication move in which the man chooses *Silence* or *Talk*. *Talk* costs 1 payoff unit, and consists of a declaration by the man that he is going to the prize fight. This declaration is just talk; it is not binding on him.

Table 6.1 Subgame Payoffs in The Expensive-Talk Game

		Woman	
		<i>Fight</i>	<i>Ballet</i>
Man:	<i>Fight</i>	3,1	0,0
	<i>Ballet</i>	0,0	1,3

Payoffs to: (Man, Woman).

(6.3a) Draw the extensive form for this game, putting the man's move first in the simultaneous-move subgame.

Answer. See Figure A.5.

Figure A.5 The Extensive Form for the "Expensive Talk Game"

Figure A.1.6 The Expensive Talk Game

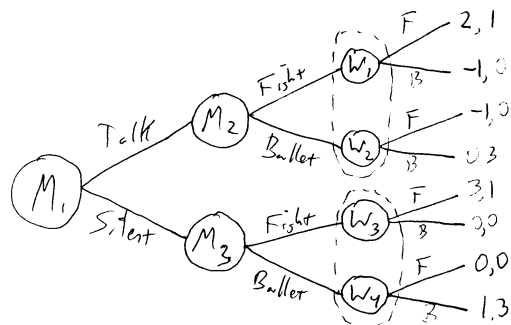

(6.3b) What are the strategy sets for the game? (start with the woman's)

Answer. The woman has two information sets at which to choose moves, and the man has three. Table A.10 shows the woman's four strategies.

Table A.10 The Woman's Strategies in "The Expensive Talk Game"

Strategy	W_1, W_2	W_3, W_4
1	F	F
2	F	B
3	B	F
4	B	B

Table A.11 shows the man's eight strategies, of which only the boldfaced four are important, since the others differ only in portions of the game tree that the man knows he will never reach unless he trembles at M_1 .

Table A.11 The Man's Strategies in "The Expensive Talk Game"

Strategy	M_1	M_2	M_3
1	T	F	F
2	T	F	B
3	T	B	B
4	T	B	F
5	S	F	F
6	S	B	F
7	S	B	B
8	S	F	B

- (6.3c) What are the three perfect pure-strategy equilibrium outcomes in terms of observed actions? (Remember: strategies are not the same thing as outcomes.)

Answer. SFF, SBB, TFF.⁷

- (6.3d) Describe the equilibrium strategies for a perfect equilibrium in which the man chooses to talk.

Answer. Woman: $(F|T, B|S)$ and Man: $(T, F|T, B|S)$.

- (6.3e) The idea of “forward induction” says that an equilibrium should remain an equilibrium even if strategies dominated in that equilibrium are removed from the game and the procedure is iterated. Show that this procedure rules out SBB as an equilibrium outcome.⁸

Answer. First delete the man’s strategy of (T, B) , which is dominated by (S, B) whatever the woman’s strategy may be. Without this strategy in the game, if the woman sees the man deviate and choose *Talk*, she knows that the man must choose *Fight*. Her strategies of $(B|T, F|S)$ and $(B|T, B|S)$ are now dominated, so let us drop those. But then the man’s strategy of (S, B) is dominated by $(T, F|T, B|S)$. The man will therefore choose to *Talk*, and the SBB equilibrium is broken.

This is a strange result. More intuitively: if the equilibrium is SBB, but the man chooses *Talk*, the argument is that the woman should

⁷The equilibrium that supports SBB is $[(S, B), (B|S, B|T)]$.

⁸See Van Damme (1989). In fact, this procedure rules out TFF (*Talk, Fight, Fight*) also.

think that the man would not do anything purposeless, so it must be that he intends to choose *Fight*. She therefore will choose *Fight* herself, and the man is quite happy to choose *Talk* in anticipation of her response. Taking forward induction one step further: TFF is not an equilibrium, because now that SBB has been ruled out, if the man chooses *Silence*, the woman should conclude it is because he thinks he can thereby get the *SFF* payoff. She decides that he will choose *Fight*, and so she will choose it herself. This makes it profitable for the man to deviate to *SFF* from *TFF*.

PROBLEMS FOR CHAPTER 7 Moral Hazard: Hidden Actions

7.1: First-Best Solutions in a Principal-Agent Model. Suppose an agent has the utility function of $U = \sqrt{w} - e$, where e can assume the levels 0 or 1. Let the reservation utility level be $\bar{U} = 3$. The principal is risk neutral. Denote the agent's wage, conditioned on output, as \underline{w} if output is 0 and \bar{w} if output is 100. Table 7.5 shows the outputs.

Table 7.5 A Moral Hazard Game

Effort	Probability of Output of		Total
	0	100	
<i>Low</i> ($e = 0$)	0.3	0.7	1
<i>High</i> ($e = 1$)	0.1	0.9	1

(7.1a) What would the agent's effort choice and utility be if he owned the firm?

Answer. The agent gets everything in this case. His utility is either

$$U(\textit{High}) = 0.1(0) + 0.9\sqrt{100} - 1 = 8 \tag{30}$$

or

$$U(\textit{Low}) = 0.3(0) + 0.7\sqrt{100} - 0 = 7. \tag{31}$$

So the agent chooses high effort and a utility of 8.

- (7.1b) If agents are scarce and principals compete for them, what will the agent's contract be under full information? His utility?

Answer. The efficient effort level is *High*, which produces an expected output of 90. The principal's profit is zero, because of competition. Since the agent is risk averse, he should be fully insured in equilibrium: $\bar{w} = \underline{w} = 90$. But he should get this only if his effort is high. Thus, the contract is $w=90$ if effort is high, $w=0$ if effort is low. The agent's utility is 8.5 ($= \sqrt{90} - 1$, rounded).

- (7.1c) If principals are scarce and agents compete to work for them, what would the contract be under full information? What will the agent's utility and the principal's profit be in this situation?

Answer. The efficient effort level is high. Since the agent is risk averse, he should be fully insured in equilibrium: $\bar{w} = \underline{w} = w$. The contract must satisfy a participation constraint for the agent, so $\sqrt{w} - 1 = 3$. This yields $w = 16$, and a utility of 3 for the agent. The actual contract specified a wage of 16 for high effort and 0 for low effort. This is incentive compatible, because the agent would get only 0 in utility if he took low effort. The principal's profit is 74 ($= 90 - 16$).

- (7.1d) Suppose that $U = w - e$. If principals are the scarce factor and agents compete to work for principals, what would the contract be when the principal cannot observe effort? (Negative wages are allowed.) What will be the agent's utility and the principal's profit be in this situation?

Answer. The contract must satisfy a participation constraint for the agent, so $U = 3$. Since effort is 1, the expected wage must equal 4. One way to produce this result is to allow the agent to keep all the output, plus 4 extra for his labor, but to make him pay the expected output of 90 for this privilege ("selling the store"). Let $\bar{w} = 14$ and $\underline{w} = -86$ (other contracts also work). Then expected utility is 3 ($= 0.1(-86) + 0.9(14) - 1 = -8.6 + 12.6 - 1$). Expected profit is 86 ($= 0.1(0 - -86) + 0.9(100 - 14) = 8.6 + 77.4$).

7.3: Why Entrepreneurs Sell Out. Suppose an agent has a utility function of $U = \sqrt{w} - e$, where e can assume the levels 0 or 2.4, and his reservation

utility is $\bar{U} = 7$. The principal is risk neutral. Denote the agent's wage, conditioned on output, as $w(0)$, $w(49)$, $w(100)$, or $w(225)$. Table 7.7 shows the output.

Table 7.7 Entrepreneurs Selling Out

Method	Probability of Output of				Total
	0	49	100	225	
<i>Safe</i> ($e = 0$)	0.1	0.1	0.8	0	1
<i>Risky</i> ($e = 2.4$)	0	0.5	0	0.5	1

(7.3a) What would the agent's effort choice and utility be if he owned the firm?

Answer. $U(\text{safe}) = 0 + 0.1\sqrt{49} + 0.8\sqrt{100} + 0 - 0 = 0.7 + 8 = 8.7$.
 $U(\text{risky}) = 0 + 0.5\sqrt{49} + 0.5\sqrt{225} - 2.4 = 3.5 + 7.5 - 2.4 = 8.6$. Therefore he will choose the safe method, $e=0$, and utility is 8.7.

(7.3b) If agents are scarce and principals compete for them, what will the agent's contract be under full information? His utility?

Answer. Agents are scarce, so $\pi = 0$. Since agents are risk averse, it is efficient to shield them from risk. If the risky method is chosen, then $w = 0.5(49) + 0.5(225) = 24.5 + 112.5 = 137$. Utility is 9.3 ($\sqrt{137} - 2.4 = 11.7 - 2.4$). If the safe method is chosen, then $w = 0.1(49) + 0.8(100) = 84.9$. Utility is $U = \sqrt{84.9} = 9.21$. Therefore, the optimal contract specifies a wage of 137 if the risky method is used and 0 (or any wage less than 49) if the safe method is used. This is better for the agent than if he ran the firm by himself and used the safe method.

(7.3c) If principals are scarce and agents compete to work for principals, what will the contract be under full information? What will the agent's utility and the principal's profit be in this situation?

Answer. Principals are scarce, so $U = \bar{U} = 7$, but the efficient effort level does not depend on who is scarce, so it is still high. The agent is

risk averse, so he is paid a flat wage. The wage satisfies the participation constraint $\sqrt{w} - 2.4 = 7$, if the method is risky. The contract specifies a wage of 88.4 (rounded) for the risky method and 0 for the safe. Profit is 48.6 ($= 0.5(49) + 0.5(225) - 88.4$).

- (7.3d) If agents are the scarce factor, and principals compete for them, what will the contract be when the principal cannot observe effort? What will the agent's utility and the principal's profit be in this situation?

Answer. A boiling in oil contract can be used. Set either $w(0) = -1000$ or $w(100) = -1000$, which induces the agent to pick the risky method. In order to protect the agent from risk, the wage should be flat except for those outputs, so $w(49) = w(225) = 137$. $\pi = 0$, since agents are scarce. $U = 9.3$, from part (b).

7.5: Worker Effort. A worker can be *Careful* or *Careless*, efforts which generate mistakes with probabilities 0.25 and 0.75. His utility function is $U = 100 - 10/w - x$, where w is his wage and x takes the value 2 if he is careful, and 0 otherwise. Whether a mistake is made is contractible, but effort is not. Risk-neutral employers compete for the worker, and his output is worth 0 if a mistake is made and 20 otherwise. No computation is needed for any part of this problem.

- (7.5a) Will the worker be paid anything if he makes a mistake?

Answer. Yes. He is risk averse, unlike the principal, so his wage should be even across states.

- (7.5b) Will the worker be paid more if he does not make a mistake?

Answer. Yes. Careful effort is efficient, and lack of mistakes is a good statistic for careful effort, which makes it useful for incentive compatibility.

- (7.5c) How would the contract be affected if employers were also risk averse?

Answer. The wage would vary more across states, because the workers should be less insured—and perhaps should even be insuring the employer.

- (7.5d) What would the contract look like if a third category, “slight mistake,” with an output of 19, occurs with probability 0.1 after *Careless* effort and with probability zero after *Careful* effort?

Answer. The contract would pay equal amounts whether or not a mistake was made, but zero if a slight mistake was made, a “boiling in oil” contract.

PROBLEMS FOR CHAPTER 8 Further Topics in Moral Hazard

8.1: Monitoring with Error. An agent has a utility function $U = \sqrt{(w)} - \alpha e$, where $\alpha = 1$ and e is either 0 or 5. His reservation utility level is $\bar{U} = 9$, and his output is 100 with low effort and 250 with high effort. Principals are risk neutral and scarce, and agents compete to work for them. The principal cannot condition the wage on effort or output, but he can, if he wishes, spend five minutes of his time, worth 10 dollars, to drop in and watch the agent. If he does that, he observes the agent *Daydreaming* or *Working*, with probabilities that differ depending on the agent’s effort. He can condition the wage on those two things, so the contract will be $\{\underline{w}, \bar{w}\}$. The probabilities are given by Table 8.1.

Table 8.1 Monitoring with Error

Effort	Probability of	
	<i>Daydreaming</i>	<i>Working</i>
<i>Low</i> ($e = 0$)	0.6	0.4
<i>High</i> ($e = 5$)	0.1	0.9

- (8.1a) What are profits in the absence of monitoring, if the agent is paid enough to make him willing to work for the principal?

Answer. Without monitoring, effort is low. The participation constraint is $9 \geq \sqrt{w} - 0$, so $w = 81$. Output is 100, so profit is 19.

- (8.1b) Show that high effort is efficient under full information.

Answer. High effort yields output of 250. $\bar{U} \geq \sqrt{w} - \alpha e$ or $9 = \sqrt{w} - 5$ is the participation constraint, so $14 = \sqrt{w}$ and $w = 196$. Profit is then

54. This is superior to the profit of 19 from low effort (and the agent is no worse off), so high effort is more efficient.

(8.1c) If $\alpha = 1.2$, is high effort still efficient under full information?

Answer. If $\alpha = 1.2$, then the wage must rise to 225, for profits of 25, so high effort is still efficient. The wage must rise to 225 because the participation constraint becomes $9 \geq \sqrt{w} - 1.2(5)$.

(8.1d) Under asymmetric information, with $\alpha = 1$, what are the participation and incentive compatibility constraints?

Answer. The incentive compatibility constraint is

$$0.6\sqrt{w} + 0.4\sqrt{\bar{w}} \leq 0.1\sqrt{w} + 0.9\sqrt{\bar{w}} - 5.$$

The participation constraint is $9 \leq 0.1\sqrt{w} + 0.9\sqrt{\bar{w}} - 5$.

(8.1e) Under asymmetric information, with $\alpha = 1$, what is the optimal contract?

Answer. From the participation constraint, $14 = 0.1\sqrt{w} + 0.9\sqrt{\bar{w}}$, and $\sqrt{\bar{w}} = \frac{14}{0.9} - (\frac{1}{9})\sqrt{w}$. The incentive compatibility constraint tells us that $0.5\sqrt{\bar{w}} = 5 + 0.5\sqrt{w}$, so $\sqrt{\bar{w}} = 10 + \sqrt{w}$. Thus,

$$10 + \sqrt{w} = 15.6 - 0.11\sqrt{w} \tag{32}$$

and $\sqrt{w} = 5.6/1.11 = 5.05$. Thus, $w = 25.5$. It follows that $\sqrt{\bar{w}} = 10 + 5.05$, so $\bar{w} = 226.5$.

8.3: Bankruptcy Constraints. A risk-neutral principal hires an agent with utility function $U = w - e$ and reservation utility $\bar{U} = 7$. Effort is either 0 or 20. There is a bankruptcy constraint: $w \geq 0$. Output is given by Table 8.4.

Table 8.4 Bankruptcy

Effort	Probability of Output of		Total
	0	400	
Low ($e = 0$)	0.5	0.5	1
High ($e = 10$)	0.2	0.8	1

- (8.3a) What would the agent's effort choice and utility be if he owned the firm?
- (8.3b) If agents are scarce and principals compete for them, what will the agent's contract be under full information? His utility?
- (8.3c) If principals are scarce and agents compete to work for them, what will the contract be under full information? What will the agent's utility be?
- (8.3d) If principals are scarce and agents compete to work for them, what will the contract be when the principal cannot observe effort? What will the payoffs be for each player?
- (8.3e) Suppose there is no bankruptcy constraint. If principals are the scarce factor and agents compete to work for them, what will the contract be when the principal cannot observe effort? What will the payoffs be for principal and agent?

8.5: Efficiency Wages and Risk Aversion.⁹ In each of two periods of work, a worker decides whether to steal amount v , and is detected with probability α and suffers legal penalty p if he, in fact, did steal. A worker who is caught stealing can also be fired, after which he earns the reservation wage w_0 . If the worker does not steal, his utility in the period is $U(w)$; if he steals, it is $U(w + v) - \alpha p$, where $U(w_0 + v) - \alpha p > U(w_0)$. The worker's marginal utility of income is diminishing: $U' > 0$, $U'' < 0$, and $\lim_{x \rightarrow \infty} U'(x) = 0$. There is no discounting. The firm definitely wants to deter stealing in each period, if at all possible.

- (8.5a) Show that the firm can indeed deter theft, even in the second period, and, in fact, do so with a second-period wage w_2^* that is higher than the reservation wage w_0 .

⁹See Rasmusen (1992c).

Answer. It is easiest to deter theft in the first period, since a high second-period wage increases the penalty of being fired. If w_2 is increased enough, however, the marginal utility of income becomes so low that $U(w_2 + v)$ and $U(w_2)$ become almost identical, and the difference is less than αP , so theft is deterred even in the second period.

- (8.5b) Show that the equilibrium second-period wage w_2^* is higher than the first-period wage w_1^* .

Answer. We already determined that $w_2 > w_0$. Hence, the worker looks hopefully towards being employed in period 2, and in Period 1 he is reluctant to risk his job by stealing. This means that he can be paid less in Period 1, even though he may still have to be paid more than the reservation wage.

PROBLEMS FOR CHAPTER 9 Adverse Selection

9.1: Insurance with Equations and Diagrams.

The text analyzes Insurance Game III using diagrams. Here, let us use equations too. Let $U(t) = \log(t)$.

- (9.1a) Give the numeric values (x, y) for the full-information separating contracts C_3 and C_4 from Figure 9.6. What are the coordinates for C_3 and C_4 ?

Answer. C_3 : $0.25x + 0.75(y - x) = 0$, and $12 - x = y - x$. Put together, these give $y = 4x/3$ and $y = 12$, so $x^* = 9$ and $y^* = 12$.

$C_3 = (3, 3)$ because $12 - 9 = 3$.

C_4 is such that $0.5x + 0.5(y - x) = 0$, and $12 - x = y - x$. Put together, these give $y = 2x$ and $y = 12$, so $x^* = 6$ and $y^* = 12$.

$C_4 = (6, 6)$ because $12 - 6 = 6$.

- (9.1b) Why is it not necessary to use the $U(t) = \log(t)$ function to find the values?

Answer. We know there is full insurance at the first-best with any risk-averse utility function, so the precise function does not matter.

- (9.1c) At the separating contract under incomplete information, C_5 , $x = 2.01$. What is y ? Justify the value 2.01 for x . What are the coordinates of C_5 ?

Answer. At C_5 , the incentive compatibility constraints require that $0.5x + 0.5(x - y) = 0$, so $y = 2x$; and $\pi_u(C_5) = \pi_u(C_3)$, so $0.25\log(12 - x) + 0.75\log(y - x) = 0.25\log(3) + 0.75\log(3)$. Solving these equations yields $x^* = 2.01$ and $y = 4.02$.

$C_5 = (9.99, 2.01)$ because $9.99 = 12 - 2.01$ and $2.01 = 4.02 - 2.01$.

- (9.1d) What is a contract C_6 that might be profitable and that would lure both types away from C_3 and C_5 ?

Answer. One possibility is $C_6 = (8, 3)$, or $x = 4, y = 7$. The utility of this to the Highs is $1.59 (=0.5\log(8) + 0.5\log(3))$, compared to $1.57 (=0.5\log(10.99) + 0.5\log(2.01))$, so the High's prefer it to C_5 , and that means the Lows will certainly prefer it. If there are not many Lows, the contract can make a profit, because if it is only Highs, the profit is $0.5 (=0.5(4) + 0.5(4 - 7))$.

9.3: Finding the Mixed-Strategy Equilibrium in a Testing Game.

Half of high school graduates are talented, producing output $a = x$, and half are untalented, producing output $a = 0$. Both types have a reservation wage of 1 and are risk neutral. At a cost of 2 to himself and 1 to the job applicant, an employer can test a graduate and discover his true ability. Employers compete with each other in offering wages but they cooperate in revealing test results, so an employer knows if an applicant has already been tested and failed. There is just one period of work. The employer cannot commit to testing every applicant.

- (9.3a) Why is there no equilibrium in which either untalented workers do not apply or the employer tests every applicant?

Answer. If no untalented workers apply, the employer would deviate and save 2 by skipping the test and just hiring everybody who applies. Then the untalented workers would start to apply. If the employer tests every applicant, however, and pays only w_H , then no untalented worker will apply. Again, the employer would deviate and skip the test.

- (9.3b) In equilibrium, the employer tests workers with probability γ and pays those who pass the test w , the talented workers all present themselves for testing, and the untalented workers present themselves with probability α . Find an expression for the equilibrium value of α in terms of w . Explain why α is independent of x .

Answer. Using the payoff equating method of calculating a mixed strategy, and remembering that one must equate player 1's payoffs to find player 2's mixing probability, we must focus on the employer's profits. In the mixed-strategy equilibrium, the employer's profits are the same whether it tests a particular worker or not. Fraction $0.5 + 0.5\alpha$ of the workers will take the test, and the employer's cost for each one that applies is 2, whether he is hired or not, so

$$\pi(\text{test}) = \left(\frac{0.5}{0.5 + 0.5\alpha}\right)(x-w) - 2 = \pi(\text{no test}) = \left(\frac{0.5}{0.5 + 0.5\alpha}\right)(x-w) + \left(\frac{0.5\alpha}{0.5 + 0.5\alpha}\right)(0-w) \quad (33)$$

which yields

$$\alpha = \frac{2}{w-2}. \quad (34)$$

The naive answer to why expression (34) does not depend on x is that α is the worker's strategy, so there is no reason why it should depend on a parameter that enters only into the employer's payoffs. That is wrong, because usually in mixed strategy equilibria that is precisely the case, because the worker is choosing his probability in a way that makes the employer indifferent between his payoffs. Rather, what is going on here is that a talented worker's productivity is irrelevant to the decision of whether to test or not. The employer already knows he will hire all the talented workers, and the question for him in deciding whether to test is how costly it is to test and how costly it is to hire untalented workers.

- (9.3c) If $x = 8$, what are the equilibrium values of α , γ , and w ?

Answer. We already have an expression for α from part (b). The next step is to find the wage. Profits are zero in equilibrium, which requires that

$$\pi(\text{no test}) = \left(\frac{0.5}{0.5 + 0.5\alpha}\right)(x-w) + \left(\frac{0.5\alpha}{0.5 + 0.5\alpha}\right)(0-w) = 0. \quad (35)$$

This implies that

$$\alpha = \frac{x - w}{w}. \quad (36)$$

Substituting $x = 8$ and solving (34) and (35) together yields $w^* = 4$ and $\alpha^* = 0.5$.

In the mixed-strategy equilibrium, the untalented worker's profits are the same whether he applies or not, so

$$\pi(\text{apply}) = \gamma(-1 + 1) + (1 - \gamma)(-1 + w) = 1. \quad (37)$$

Substituting $w = 4$ and solving for γ yields $\gamma^* = \frac{2}{3}$.

9.5: Insurance and State-Space Diagrams. Two types of risk-averse people, clean-living and dissolute, would like to buy health insurance. Clean-living people become sick with probability 0.3, and dissolute people with probability 0.9. In state-space diagrams with the person's wealth if he is healthy on the vertical axis and if he is sick on the horizontal, every person's initial endowment is (5,10), because his initial wealth is 10 and the cost of medical treatment is 5.

(9.5a) What is the expected wealth of each type of person?

Answer. $E(W_c) = 8.5 (= 0.7(10) + 0.3(5))$. $E(W_d) = 5.5 (= 0.1(10) + 0.9(5))$.

(9.5b) Draw a state-space diagram with the indifference curves for a risk-neutral insurance company that insures each type of person separately. Draw in the post-insurance allocations C_1 for the dissolute and C_2 for the clean-living under the assumption that a person's type is contractible.

Answer. See Figure A.6.

Figure A.6 A State-Space Diagram Showing Indifference Curves for the Insurance Company

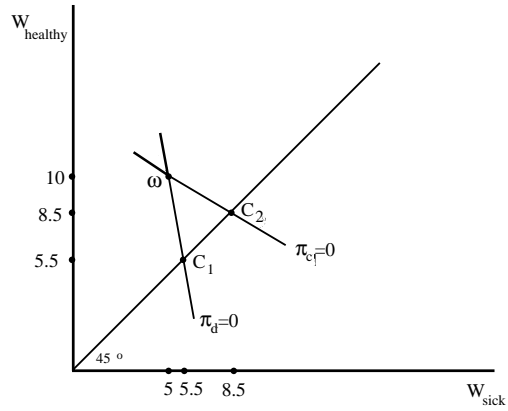

- (9.5c) Draw a new state-space diagram with the initial endowment and the indifference curves for the two types of people that go through that point.

Answer. See Figure A.7.

Figure A.7 A State-Space Diagram Showing Indifference Curves for the Customers

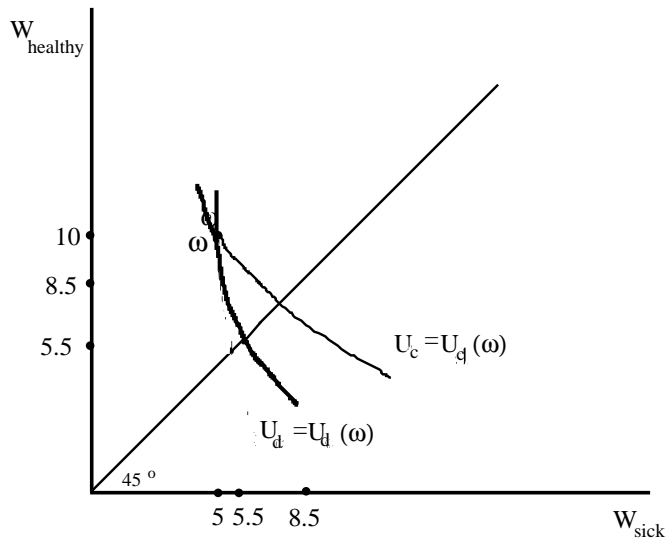

(9.5d) Explain why, under asymmetric information, no pooling contract C_3 can be part of a Nash equilibrium.

Answer. Call the pooling contract C_3 . Because indifference curves for the clean-living are flatter than for the dissipated, a contract C_4 can be found which yields positive profits because it attracts the clean-living but not the dissipated. See Figure A.8.

Figure A.8 Why A Pooling Contract Cannot be Part of an Equilibrium

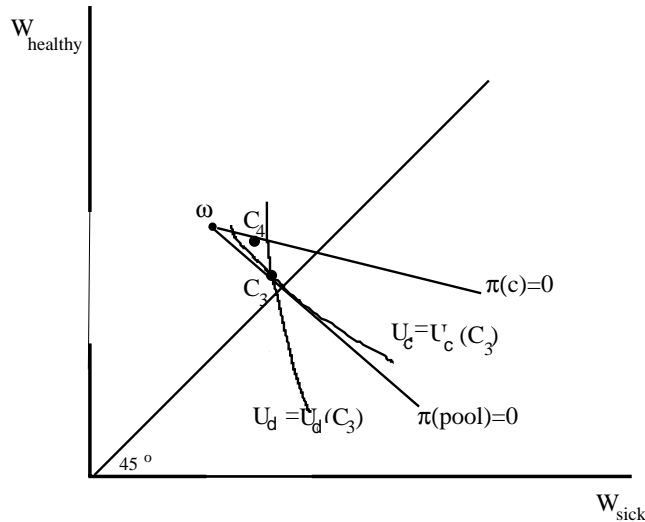

- (9.5e) If the insurance company is a monopoly, can a pooling contract be part of a Nash equilibrium?

Answer. Yes. If the insurance company is a monopoly, then a pooling contract can be part of a Nash equilibrium, because there is no other player who might deviate by offering a cream-skimming contract.

PROBLEMS FOR CHAPTER 9a Mechanism Design in Adverse Selection
and in Moral Hazard with Hidden Information

9a.1: Unravelling (formerly Problem 8.3). An elderly prospector owns a gold mine worth an amount θ drawn from the uniform distribution $U[0, 100]$ which nobody knows, including himself. He will certainly sell the mine, since he is too old to work it and it has no value to him if he does not sell it. The several prospective buyers are all risk neutral. The prospector can, if he desires, dig deeper into the hill and collect a sample of gold ore that will reveal the value of θ . If he shows the ore to the buyers, however, he must show genuine ore, since an unwritten Law of the West says that fraud is punished by hanging offenders from Joshua trees as food for buzzards.

- (9a.1a) For how much can he sell the mine if he is clearly too feeble to have dug into the hill and examined the ore? What is the price in this situation if, in fact, the true value is $\theta = 70$?

Answer. The price is 50 – the expected value of the uniform distribution from 0 to 100. Even if the mine is actually worth $\theta = 70$, the price remains at 50.

- (9a.1b) For how much can he sell the mine if he can dig the test tunnel at zero cost? Will he show the ore? What is the price in this situation if, in fact, the true value is $\theta = 70$?

Answer. The expected price is 50. Unravelling occurs, so he will show the ore, and the buyer can discover the true value, which is 50 on average. If the true value is $\theta = 70$, the buyer receives 70.

- (9a.1c) For how much can he sell the mine if, after digging the tunnel at zero cost and discovering θ , it costs him an additional 10 to verify the results for the buyers? What is his expected payoff?

Answer. He shows the ore iff $\theta \in [20, 100]$. This is because if the minimum quality ore he shows is b , then the price at which he can sell the mine without showing the ore is $\frac{b}{2}$. If $b = 20$ and the true value is 20, then he can sell the mine for 10, and showing the ore to raise the price to 20 would not increase his net profit, given the display cost of 10.

With probability 0.2, his price is 10, and with probability 0.8, it is an average price of 60 but he pays 10 to display the ore. Thus, the prospector's expected payoff is 42 ($= 0.2(10) + 0.8(60 - 10) = 2 + 40 = 42$.)

- (9a.1d) What is the prospector's expected payoff if with probability 0.5 digging the tunnel is costless, but with probability 0.5 it costs 120?

Answer. In equilibrium there exists some number c such that if the prospector has dug the tunnel and found the value of the mine to be $\theta \geq c$ he will show the ore. If he does not show any ore, the buyers' expected value for the mine is $0.5 \left(\frac{100-0}{2} \right) + 0.5 \left(\frac{c-0}{2} \right) = \frac{c}{4} + 25$. Having dug the tunnel, he will therefore show the ore if $\theta \geq \frac{c}{4} + 25$, because then he can get a price of θ instead. Since c is defined as the minimal

level he will disclose, it follows that $c = \frac{c}{4} + 25$, which implies that $c = 33 \frac{1}{3}$ (and the price is $(\frac{1}{4})(33 \frac{1}{3}) + 25 = 33 \frac{1}{3}$ if he does not show the ore).

With probability 0.5, the prospector will not dig the tunnel, and will receive a price of $33 \frac{1}{3}$. With probability 0.5 he will dig the tunnel, and will refuse to disclose with probability $\frac{1}{3}$, for a price of $33 \frac{1}{3}$, and disclose with probability $\frac{2}{3}$, for an average price of $66 \frac{2}{3}$, for an expected payoff of about 44.4.

9a.3: Agency Law. Mr. Smith is thinking of buying a custom-designed machine from either Mr. Jones or Mr. Brown. This machine costs 5000 dollars to build, and it is useless to anyone but Smith. It is common knowledge that with 90 percent probability the machine will be worth 10,000 dollars to Smith at the time of delivery, one year from today, and with 10 percent probability it will only be worth 2,000 dollars. Smith owns assets of 1,000 dollars. At the time of contracting, Jones and Brown believe there is there is a 20 percent chance that Smith is actually acting as an “undisclosed agent” for Anderson, who has assets of 50,000 dollars.

Find the price be under the following two legal regimes: (a) An undisclosed principal is not responsible for the debts of his agent; and (b) even an undisclosed principal is responsible for the debts of his agent. Also, explain (as part [c]) which rule a moral hazard model like this would tend to support.

Answer. (a) The zero profit condition, arising from competition between Jones and Brown, is

$$- 5000 + .9P + .1(1000) = 0, \tag{38}$$

because Smith will only pay for the machine with probability 0.9, and otherwise will default and only pay up to his wealth, which is 1. This yields $P \approx 5,444$.

(b) If Anderson is responsible for Smith’s debts, then Smith will pay the 5,000 dollars. Hence, zero profits require

$$- 5000 + .9P + .1(.2)P + .1(.8)(1000) = 0, \tag{39}$$

which yields $P \approx 5,348$.

(c) Moral hazard tends to support rule (b). This is because it reduces bankruptcy and the agent will be more reluctant to order the machine when there is a high chance it is unprofitable. In the model as constructed, this does not arise, because there is only one type of agent, but more generally it would, because there would be a continuum of types of agents, and some who would buy the machine under rule (b) would find it too expensive under rule (a).

Even in the model as it stands, rule (a) leads to the inefficient outcome that a machine worth 2,000 to Smith is not given to Smith. Rather, he pays his wealth and lets the seller keep the machine, which is inefficient since the machine really is worth 2000 to Smith.

Nobody in my class answered this question correctly, which surprised me. It basically is a question about zero-profit prices. Guessing would have been a good idea here: it is very intuitive that the price would always be above \$5,000, and that it would be higher if the principal never had to cover the agent's debts. You should be able to tell that $P > 10,000$ is impossible, because Smith would never pay it. Also, the sellers compete, so it is their profits that provide a participation constraint, not the benefit to the buyer.

PROBLEMS FOR CHAPTER 10 Signalling¹⁰

10.1: Is Lower Ability Better? Change Education I so that the two possible worker abilities are $a \in \{1, 4\}$.

(10.1a) What are the equilibria of this game? What are the payoffs of the workers (and the payoffs averaged across workers) in each equilibrium?

Answer. The pooling equilibrium is

$$y_L = y_H = 0, w_0 = w_1 = 2.5, Pr(L|y = 1) = 0.5, \quad (40)$$

¹⁰xxx Check on whether y should be s , for signal.

which uses passive conjectures. The payoffs are $U_L = U_H = 2.5$, for an average payoff of 2.5.

The separating equilibrium is

$$y_L = 0, y_H = 1, w_0 = 1, w_1 = 4. \quad (41)$$

The payoffs are $U_L = 1$ and $U_H = 2$, for an average payoff of 1.5. This equilibrium can be justified by the self selection constraints

$$U_L(y = 0) = 1 > U_L(y = 1) = 4 - 8/1 = -4 \quad (42)$$

and

$$U_H(y = 0) = 1 < U_H(y = 1) = 4 - 8/4 = 2. \quad (43)$$

(10.1b) Apply the Intuitive Criterion (see N6.2). Are the equilibria the same?

Answer. Yes. The intuitive criterion does not rule out the pooling equilibrium in the game with $a_h = 4$. There is no incentive for *either* type to deviate from $y = 0$ even if the deviation makes the employers think that the deviator is high-ability. The payoff to a persuasive high-ability deviator is only 2, compared the 2.5 that he can get in the pooling equilibrium.

(10.1c) What happens to the equilibrium worker payoffs if the high-ability is 5 instead of 4?

Answer. The pooling equilibrium is

$$y_L = y_H = 0, w_0 = w_1 = 5, Pr(L|y = 1) = 0.5, \quad (44)$$

which uses passive conjectures. The payoffs are $U_L = U_H = 3$, with an average payoff of 3.

The separating equilibrium is

$$y_L = 0, y_H = 1, w_0 = 1, w_1 = 5. \quad (45)$$

The payoffs are $U_L = 1$ and $U_H = 3.4$ with an average payoff of 2.2. The self selection constraints are

$$U_H(y = 0) = 1 < U_H(y = 1) = 5 - \frac{8}{5} = 3.4 \quad (46)$$

and

$$U_L(y = 0) = 1 > U_L(y = 1) = 5 - \frac{8}{1} = -3. \quad (47)$$

- (10.1d) Apply the Intuitive Criterion to the new game. Are the equilibria the same?

Answer. **No.** The strategy of choosing $y = 1$ is dominated for the Lows, since its maximum payoff is -3 , even if the employer is persuaded that he is High. So only the separating equilibrium survives.

- (10.1e) Could it be that a rise in the maximum ability reduces the average worker's payoff? Can it hurt all the workers?

Answer. **Yes.** Rising ability would reduce the average worker payoff if the shift was from a pooling equilibrium when $a_h = 4$ to a separating equilibrium when $a_h = 5$. Since the Intuitive Criterion rules out the pooling equilibrium when $a_h = 5$, it is plausible that the equilibrium is separating when $a_h = 5$. Since the pooling equilibrium is pareto-dominant when $a_h = 4$, it is plausible that it is the equilibrium played out. So the average payoff may well fall from 2.5 to 2.2 when the high ability rises from 4 to 5. **This cannot make every player worse off**, however; the high-ability workers see their payoffs rise from 2.5 to 3.4.

10.3: Price and Quality. Consumers have prior beliefs that Apex produces low-quality goods with probability 0.4 and high-quality with probability 0.6. A unit of output costs 1 to produce in either case, and it is worth 10 to the consumer if it is high-quality and 0 if low-quality. The consumer, who is risk neutral, decides whether to buy in each of two periods, but he does not know the quality until he buys. There is no discounting.

- (10.3a) What is Apex' price and profit if it must choose one price, p^* , for both periods?

Answer. A consumer's expected consumer surplus is

$$CS = 0.4(0 - p^*) + 0.6(10 - p^*) + 0.6(10 - p^*) = -1.6p^* + 12. \quad (48)$$

Apex maximizes its profits by setting $CS = 0$, in which case $p^* = 7.5$ and profit is $\pi_H = 13$ ($= 2(7.5 - 1)$) or $\pi_L = 6.5$ ($= 7.5 - 1$).

- (10.3b) What is Apex' price and profit if it can choose two prices, p_1 and p_2 , for the two periods, but it cannot commit ahead to p_2 ?

Answer. If Apex is high quality, it will choose $p_2 = 10$, since the consumer, having learned the quality first period, is willing to pay that much. Thus consumer surplus is

$$CS = 0.4(0 - p_1) + 0.6(10 - p_1) + 0.6(10 - 10) = -p_1 + 6, \quad (49)$$

and, setting this equal to zero, $p_1 = 6$, for a profit of $\pi_H = 14 (= (6-1) + (10-1))$ or $\pi_L = 5 (= 6-1)$.

- (10.3c) What is the answer to part (b) if the discount rate is $r = 0.1$?

Answer. Apex cannot do better than the prices suggested in part (b).

- (10.3d) Returning to $r = 0$, what if Apex can commit to p_2 ?

Answer. Commitment makes no difference in this problem, since Apex wants to charge a higher price in the second period anyway if it has high quality— a high price in the first period would benefit the low-quality Apex too, at the expense of the high-quality Apex.

- (10.3e) How do the answers to (a) and (b) change if the probability of low quality is 0.95 instead of 0.4? (There is a twist to this question.)

Answer. With a constant price, a consumer's expected consumer surplus is

$$CS = 0.95(0 - p^*) + 0.05(10 - p^*) + 0.05(10 - p^*) = -1.05p^* + 0.5 \quad (50)$$

Apex would set $CS = 0$, in which case $p^* = \frac{5}{21}$, but since this is less than cost, Apex in fact would not sell anything at all, and would earn zero profit.

With changing prices, high-quality Apex will choose $p_2 = 10$, since the consumer, having learned the quality first period, is willing to pay that much. Thus consumer surplus is

$$CS = 0.95(0 - p_1) + 0.05(10 - p_1) + 0.05(10 - 10) = -p_1 + 0.5. \quad (51)$$

and, setting this equal to zero, you might think that $p_1 = 0.5$, for a profit of $\pi_H = 8.5 (= (0.5 - 1) + (10 - 1))$. But notice that if the low-quality Apex tries to follow this strategy, his payoff is $\pi_L = 0.5 - 1 < 0$.

Hence, only the high-quality Apex will try it. But then the consumers know the product is high-quality, and they are willing to pay 10 even in the first period. What the high-quality Apex can do is charge up to $p_1 = 1$ in the first period, for profits of 9 ($= (1 - 1) + (10 - 1)$).

10.5: Advertising. Brydox introduces a new shampoo which is actually very good, but is believed by consumers to be good with only a probability of 0.5. A consumer would pay 10 for high quality and 0 for low quality, and the shampoo costs 6 per unit to produce. The firm may spend as much as it likes on stupid TV commercials showing happy people washing their hair, but the potential market consists of 100 cold-blooded economists who are not taken in by psychological tricks. The market can be divided into two periods.

(10.5a) If advertising is banned, will Brydox go out of business?

Answer. No. It can sell at a price of 5 in the first period and 10 in the second period. This would yield profits of 300 ($= (100)(5-6) + (100)(10-6)$).

(10.5b) If there are two periods of consumer purchase, and consumers discover the quality of the shampoo if they purchase in the first period, show that Brydox might spend substantial amounts on stupid commercials.

Answer. If the seller produces high quality, it can expect repeat purchases. This makes expenditure on advertising useful if it increases the number of initial purchases, even if the firm earns losses in the first period. If the seller produces low quality, there will be no repeat purchases. Hence, advertising expenditure can act as a signal of quality: consumers can view it as a signal that the seller intends to stay in business two periods.

(10.5c) What is the minimum and maximum that Brydox might spend on advertising, if it spends a positive amount?

Answer. If there is a separating signalling equilibrium, it will be as follows. Brydox would spend nothing on advertising if its shampoo is low quality, and consumers will not buy from any company that

advertises less than some amount X , because such a company is believed to produce low quality. Brydox would spend X on advertising if its quality is high, and charge a price of 10 in both periods.

Amount X is between 400 and 500. If a low-quality firm spends X on advertising, consumers do buy from it for one period, and it earns profits of $(100)(10-6)-X = 400-X$. Thus, the high-quality firm must spend at least 400 to distinguish itself. If a high-quality firm spends X on advertising, consumers buy from it for both periods, and it earns profits of $(2)(100)(10-6)-X = 800-X$. Since it can make profits of 300 even without advertising, a high-quality firm will spend up to 500 on advertising.

PROBLEMS FOR CHAPTER 11 Bargaining

11.1: A Fixed Cost of Bargaining and Grudges. Smith and Jones are trying to split 100 dollars. In bargaining round 1, Smith makes an offer at cost 0, proposing to keep S_1 for himself and Jones either accepts (ending the game) or rejects. In round 2, Jones makes an offer at cost 10 of S_2 for Smith and Smith either accepts or rejects. In round 3, Smith makes an offer of S_3 at cost c , and Jones either accepts or rejects. If no offer is ever accepted, the 100 dollars goes to a third player, Dobbs.

(11.1a) If $c = 0$, what is the equilibrium outcome?

Answer. $S_1 = 100$ and Jones accepts it. If Jones refused, he would have to pay 10 to make a proposal that Smith would reject, and then Smith would propose $S_3 = 100$ again. $S_1 < 100$ would not be an equilibrium, because Smith could deviate to $S_1 = 100$ and Jones would still be willing to accept.

(11.1b) If $c = 80$, what is the equilibrium outcome?

Answer. If the game goes to Round 3, Smith will propose $S_3 = 100$ and Jones will accept, but this will cost Smith 80. Hence, if Jones proposes $S_2 = 20$, Smith will accept it, leaving 80 for Jones—who would, however pay 10 to make his offer. Hence, in Round 1 Smith must offer $S_1 = 30$ to induce Jones to accept, and that will be the equilibrium outcome.

(11.1c) If $c = 10$, what is the equilibrium outcome?

Answer. If the game goes to Round 3, Smith will propose $S_3 = 100$ and Jones will accept, but this will cost Smith 10. Hence, if Jones proposes $S_2 = 90$, Smith will accept it, leaving 10 for Jones—who would, however pay 10 to make his offer. Hence, in Round 1 Smith need only offer $S_1 = 100$ to induce Jones to accept, and that will be the equilibrium outcome.

(11.1d) What happens if $c = 0$, but Jones is very emotional and would spit in Smith's face and throw the 100 dollars to Dobbs if Smith proposes $S = 100$? Assume that Smith knows Jones's personality perfectly.

Answer. However emotional Jones may be, there is some minimum offer M that he would accept, which probably is less than 50 (but you never know—some people think they are entitled to everything, and one could imagine a utility function such that Jones would refuse $S = 5$ and prefer to bear the cost 10 in the second round in order to get the whole 100 dollars). The equilibrium will be for Smith to propose exactly $S - M$ in Round 1, and for Jones to accept.

11.3: The Nash Bargaining Solution. Smith and Jones, shipwrecked on a desert island, are trying to split 100 pounds of cornmeal and 100 pints of molasses, their only supplies. Smith's utility function is $U_s = C + 0.5M$ and Jones' is $U_j = 3.5C + 3.5M$. If they cannot agree, they fight to the death, with $U = 0$ for the loser. Jones wins with probability 0.8.

(11.3a) What is the threat point?

Answer. The threat point gives the expected utility for Smith and Jones if they fight. This is 560 for Jones ($= 0.8(350 + 350) + 0$), and 30 for Smith ($= 0.2(100 + 50) + 0$).

(11.3b) With a 50-50 split of the supplies, what are the utilities if the two players do not recontract? Is this efficient?

Answer. The split would give the utilities $U_s = 75$ ($= 50 + 25$) and $U_j = 350$. If Smith then traded 10 pints of molasses to Jones for 8

pounds of cornmeal, the utilities would become $U_s = 78 (= 58+20)$ and $U_j = 357 (=3.5(60) + 3.5(42))$, so both would have gained. The 50-50 split is not efficient.

- (11.3c) Draw the threat point and the Pareto frontier in utility space (put U_s on the horizontal axis).

Answer. See Figure A.9.

Figure A.9 The Threat Point and Pareto Frontier

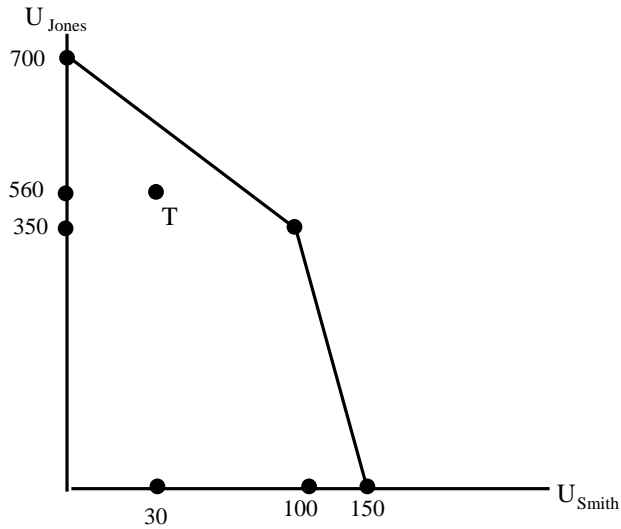

To draw the diagram, first consider the extreme points. If Smith gets everything, his utility is 150 and Jones's is 0. If Jones gets everything, his utility is 700 and Smith's is 0. If we start at $(150,0)$ and wish to efficiently help Jones at the expense of Smith, this is done by giving Jones some molasses, since Jones puts a higher relative value on molasses. This can be done until Jones has all the molasses, at utility point $(100, 350)$. Beyond there, one must take cornmeal away from Smith if one is to help Jones further, so the Pareto frontier acquires a flatter slope.

- (11.3d) According to the Nash bargaining solution, what are the utilities? How are the goods split?

Answer. To find the Nash bargaining solution, maximize $(U_s - 30)(U_j - 560)$. Note from the diagram that it seems the solution will be on the upper part of the Pareto frontier, above $(100, 350)$, where Jones is consuming all the molasses, and where if Smith loses one utility unit, Jones gets 3.5. If we let X denote the amount of cornmeal that Jones gets, we can rewrite the problem as

$$\underset{X}{\text{Maximize}} (100 - X - 30)(350 + 3.5X - 560) \quad (52)$$

This maximand equals $(70 - X)(3.5X - 210) = -14,700 + 455X - 3.5X^2$. The first order condition is $455 - 7X = 0$, so $X^* = 65$. Thus, Smith gets 35 pounds of cornmeal, Jones gets 65 pounds of cornmeal and 100 of molasses, and $U_s = 35$ and $U_j = 577.5$.

- (11.3e) Suppose Smith discovers a cookbook full of recipes for a variety of molasses candies and corn muffins, and his utility function becomes $U_s = 10C + 5M$. Show that the split of goods in part (d) remains the same despite his improved utility function.

Answer. The utility point at which Jones has all the molasses and Smith has the molasses is now $(1000, 350)$, since Smith's utility is $(10)(100)$. Smith's new threat point utility is $300 (= 0.2((10)(100) + (5)(100)))$. Thus, the Nash problem of equation (52) becomes

$$\underset{X}{\text{Maximize}} (1000 - 10X - 300)(350 + 3.5X - 560). \quad (53)$$

But this maximand is the same as $(10)(100 - X - 30)(350 + 3.5X - 560)$, so it must have the same solution as was found in part (d).

11.5: A Fixed Cost of Bargaining and Incomplete Information.

Smith and Jones are trying to split 100 dollars. In bargaining round 1, Smith makes an offer at cost c , proposing to keep S_1 for himself. Jones either accepts (ending the game) or rejects. In round 2, Jones makes an offer of S_2 for Smith, at cost 10, and Smith either accepts or rejects. In round 3, Smith makes an offer of S_3 at cost c , and Jones either accepts or rejects. If no offer is ever accepted, the 100 dollars goes to a third player, Parker.

(11.5a) If $c = 0$, what is the equilibrium outcome?

Answer. Answer. $S_1 = 100$ and Jones accepts it. If Jones refused, he would have to pay 10 to make a proposal that Smith would reject, and then Smith would propose $S_3 = 100$ again. $S_1 < 100$ would not be an equilibrium, because Smith could deviate to $S_1 = 100$ and Jones would still be willing to accept.

(11.5b) If $c = 80$, what is the equilibrium outcome?

Answer. If the game goes to Round 3, Smith will propose $S_3 = 100$ and Jones will accept, but this will cost Smith 80. Hence, if Jones proposes $S_2 = 20$, Smith will accept it, leaving 80 for Jones—who would, however, pay 10 to make his offer. Hence, in Round 1 Smith must offer $S_1 = 30$ to induce Jones to accept, which will be the equilibrium outcome.

(11.5c) If Jones' priors are that $c = 0$ and $c = 80$ are equally likely, but only Smith knows the true value, what is the equilibrium outcome? (Hint: the equilibrium uses mixed strategies.)

Answer. Smith's equilibrium strategy is to offer $S_1 = 100$ with probability 1 if $c = 0$ and probability $\frac{1}{7}$ if $c = 80$; to offer $S_1 = 30$ with probability $\frac{6}{7}$ if $c = 80$. He accepts $S_2 \geq 20$ if $c = 80$ and $S_2 = 100$ if $c = 0$, and proposes $S_3 = 100$ regardless of c . Jones accepts $S_1 = 100$ with probability $\frac{1}{8}$, rejects $S_1 \in (30, 100)$, and accepts $S_1 \leq 30$. He proposes $S_2 = 20$ and accepts $S_3 = 100$. Out of equilibrium, a supporting belief for Jones to believe that if S_1 equals neither 30 nor 100, then $Prob(c = 80) = 1$.

If $c = 0$, the equilibrium outcome is for Smith to propose $S_1 = 100$, for Jones to accept with probability $\frac{1}{8}$ and to propose $S_2 = 20$ otherwise and be rejected, and for Smith to then propose $S_3 = 100$ and be accepted. If $c = 80$, the equilibrium outcome is with probability $\frac{6}{7}$ for Smith to propose $S_1 = 30$ and be accepted, with probability $(\frac{1}{7})(\frac{1}{8})$ to propose $S_1 = 100$ and be accepted, and with probability $(\frac{1}{7})(\frac{7}{8})$ to propose $S_1 = 100$, be rejected, and then to be proposed $S_2 = 20$ and to accept.

The rationale behind the equilibrium strategies is as follows. In Round 3, either type of Smith does best by proposing a share of 100, and Jones

might as well accept. In Round 2, anything but $S_2 = 100$ would be rejected by Smith if $c = 0$, so Jones should give up on that and offer $S_2 = 20$, which would be accepted if $c = 80$ because if that type of Smith were to wait, he would have to pay 80 to propose $S_3 = 100$. In Round 1, if $c = 0$, Smith should propose $S_1 = 100$, since he can wait until Round 3 and get that anyway at zero extra cost. There is no pure strategy equilibrium, because if $c = 80$, Smith would pretend that $c = 0$ and propose $S_1 = 100$ if Jones would accept that. But if Jones accepts only with probability θ , then Smith runs the risk of only getting 20 in the second period, less than $S_1 = 30$, which would be accepted by Jones with probability 1. Similarly, if Smith proposes $S_1 = 100$ with probability γ when $c = 80$, Jones can either accept it, or wait, in which case Jones might either pay a cost of 10 and end up with $S_3 = 100$ anyway, or get Smith to accept $S_2 = 20$.

The probability γ must equate Jones's two pure-strategy payoffs. Using Bayes's Rule for the probabilities in (55), the payoffs are¹¹

$$\pi_j(\text{accept } S_1 = 100) = 0 \quad (54)$$

and

$$\pi_j(\text{reject } S_1 = 100) = -10 + \left(\frac{0.5\gamma}{0.5\gamma + 0.5} \right) (80) + \left(\frac{0.5}{0.5\gamma + 0.5} \right) (0), \quad (55)$$

which yields $\gamma = \frac{1}{7}$.

The probability θ must equate Smith's two pure-strategy payoffs:

$$\pi_s(S_1 = 30) = 30 \quad (56)$$

and

$$\pi_s(S_1 = 100) = \theta 100 + (1 - \theta) 20, \quad (57)$$

which yields $\theta = \frac{1}{8}$.

11.7: Myerson-Satterthwaite. The owner of a tract of land values his land at v_s and a potential buyer values it at v_b . The buyer and seller do not

¹¹xxx Fixed up, Jyly 23, 1993.

know each other's valuations, but guess that they are uniformly distributed between 0 and 1. The seller and buyer suggest p_s and p_b simultaneously, and they have agreed that the land will be sold to the buyer at price $p = \frac{(p_b + p_s)}{2}$ if $p_s \geq p_b$.

The actual valuations are $v_s = .2$ and $v_b = .8$. What is one equilibrium outcome given these valuations and this bargaining procedure? Explain why this can happen.

Answer. xxx

PROBLEMS FOR CHAPTER 12 Auctions

12.1: Rent-Seeking. Two risk-neutral neighbors in 16th century England, Smith and Jones, have gone to court and are considering bribing a judge. Each of them makes a gift, and the one whose gift is the largest is awarded property worth £2,000. If both bribe the same amount, the chances are 50 percent for each of them to win the lawsuit. Gifts must be either £0, £900, or £2,000.

12.1a) (What is the unique pure-strategy equilibrium for this game?

Answer. Each bids £900, for expected profits of 100 each ($= -900 + 0.5(2000)$). Table A.12 shows the payoffs (but also includes the payoffs for when the strategy of a bid of 1500 is allowed). A player who deviates to 0 has a payoff of 0; a player who deviates to 2000 has a payoff of 0. (0,0) is not an equilibrium, because the expected payoff is 1000, but a player who deviated to 900 would have a payoff of 1100.

Table A.12 “Bribes I”

		Jones			
		$\pounds 0$	$\pounds 900$	$\pounds 1500$	$\pounds 2000$
Smith:	$\pounds 0$	1000,1000	0,1100	0,500	0,0
	$\pounds 900$	1100,0	100,100	-900, 500	-900,0
	$\pounds 1500$	500,0	500,-900	-500,-500	-1500,0
	$\pounds 2000$	0,0	0,-900	0,-1500	-1000,-1000

Payoffs to: (Smith, Jones).

- (12.1b) Suppose that it is also possible to give a $\pounds 1500$ gift. Why does there no longer exist a pure-strategy equilibrium?

Answer. If Smith bids 0 or 900, Jones would bid 1500. If Smith bids 1500, Jones would bid 2000. If both bid 2000, then one can profit by deviating to 0. But if Smith bids 2000 and Jones bids 0, Smith will deviate to 900. This exhausts all the possibilities.

- (12.1c) What is the symmetric mixed-strategy equilibrium for the expanded game? What is the judge's expected payoff?

Answer. Let $(\theta_0, \theta_{900}, \theta_{1500}, \theta_{2000})$ be the probabilities. It is pointless ever to bid 2000, because it can only yield zero or negative profits, so $\theta_{2000} = 0$. In a symmetric mixed-strategy equilibrium, the return to the pure strategies is equal, and the probabilities add up to one, so

$$\pi_{Smith}(0) = \pi_{Smith}(900) = \pi_{Smith}(1500)$$

$$0.5\theta_0(2000) = -900 + \theta_0(2000) + 0.5\theta_{900}(2000) = -1500 + \theta_0(2000) + \theta_{900}(2000) + 0.5\theta_{1500}(2000) \quad (58)$$

and

$$\theta_0 + \theta_{900} + \theta_{1500} = 1. \quad (59)$$

Solving out these three equations for three unknowns, the equilibrium is $(0.4, 0.5, 0.1, 0.0)$.

The judge's expected payoff is 1200 $(=2(0.5(900) + 0.1(1500)))$

Note: The results are sensitive to the bids allowed. Can you speculate as to what might happen if the strategy space were the whole continuum from 0 to 2000?

(12.1d) In the expanded game, if the losing litigant gets back his gift, what are the two equilibria? Would the judge prefer this rule?

Answer. Table A.13 shows the new outcome matrix. There are three equilibria: $x_1 = (900, 900)$, $x_2 = (1500, 1500)$, and $x_3 = (2000, 2000)$.

Table A.13 “Bribes II”

		Jones			
		£0	£900	£1500	£2000
Smith:	£0	1000, 1000	0, 1100	0, 500	0, 0
	£900	1100, 0	550, 550	0, 500	0, 0
	£1500	500, 0	500, 0	250, 250	0, 0
	£2000	0, 0	0, 0	0, 0	0, 0

Payoffs to: (Smith, Jones).

The judge’s payoff was 1200 under the unique mixed-strategy equilibrium in the original game. Now, his payoff is either 900, 1500, or 2000. Thus, whether he prefers the new rules depends on which equilibrium is played out in it.

12.3: Government and Monopoly. Incumbent Apex and potential entrant Brydox are bidding for government favors in the widget market. Apex wants to defeat a bill that would require it to share its widget patent rights with Brydox. Brydox wants the bill to pass. Whoever offers the chairman of the House Telecommunications Committee more campaign contributions wins, and the loser pays nothing. The market demand curve is $P = 25 - Q$, and marginal cost is constant at 1.

(12.3a) Who will bid higher if duopolists follow Bertrand behavior? How much will the winner bid?

Answer. Apex bids higher, because it gets monopoly profits from winning, and Bertrand profits equal zero. Apex can bid some small ϵ and win.

- (12.3b) Who will bid higher if duopolists follow Cournot behavior? How much will the winner bid?

Answer. Monopoly profits are found from the problem

$$\text{Maximize}_{Q_a} \quad Q_a(25 - Q_a - 1), \quad (60)$$

which has the first order condition $25 - 2Q_a - 1 = 0$, so that $Q_a = 12$ and $\pi_a = 144 (= 12(25 - 12 - 1))$.

Each firm's Cournot duopoly profits are found from the problem

$$\text{Maximize}_{Q_a} \quad Q_a(25 - Q_a - Q_b - 1), \quad (61)$$

which has the first order condition $25 - 2Q_a - Q_b - 1 = 0$, so that if the equilibrium is symmetric and $Q_b = Q_a$, then $Q_a = 8$ and $\pi_a = 48 (= 12(25 - 8 - 8 - 1)/2)$.¹²

Brydox will bid up to 48. Apex will bid up to $96 (= 144 - 48)$, and so Apex will win the auction at a price of 48.

- (12.3c) What happens under Cournot behavior if Apex can commit to giving away its patent freely to everyone in the world if the entry bill passes? How much will Apex bid?

Answer. Apex will bid some small ϵ and win. It will commit to giving away its patent if the bill succeeds, which means that if the bill succeeds, the industry will have zero profits and Brydox has no incentive to bid a positive amount to secure entry.

PROBLEMS FOR CHAPTER 13 Pricing

13.1: Differentiated Bertrand with Advertising. Two firms that produce substitutes are competing with demand curves

$$q_1 = 10 - \alpha p_1 + \beta p_2 \quad (62)$$

and

$$q_2 = 10 - \alpha p_2 + \beta p_1. \quad (63)$$

Marginal cost is constant at $c = 3$. A player's strategy is his price. Assume that $\alpha > \beta/2$.

¹²xxx 48 is not correct. The profit equation is wrong.

- (13.1a) What is the reaction function for Firm 1? Draw the reaction curves for both firms.

Answer. Firm 1's profit function is

$$\pi_1 = (p_1 - c)q_1 = (p_1 - 3)(10 - \alpha p_1 + \beta p_2). \quad (64)$$

Differentiating with respect to p_1 and solving the first order condition gives the reaction function

$$p_1 = \frac{10 + \beta p_2 + 3\alpha}{2\alpha}. \quad (65)$$

This is shown in Figure A.10.

Figure A.10 The Reaction Curves in a Bertrand Game with Advertising

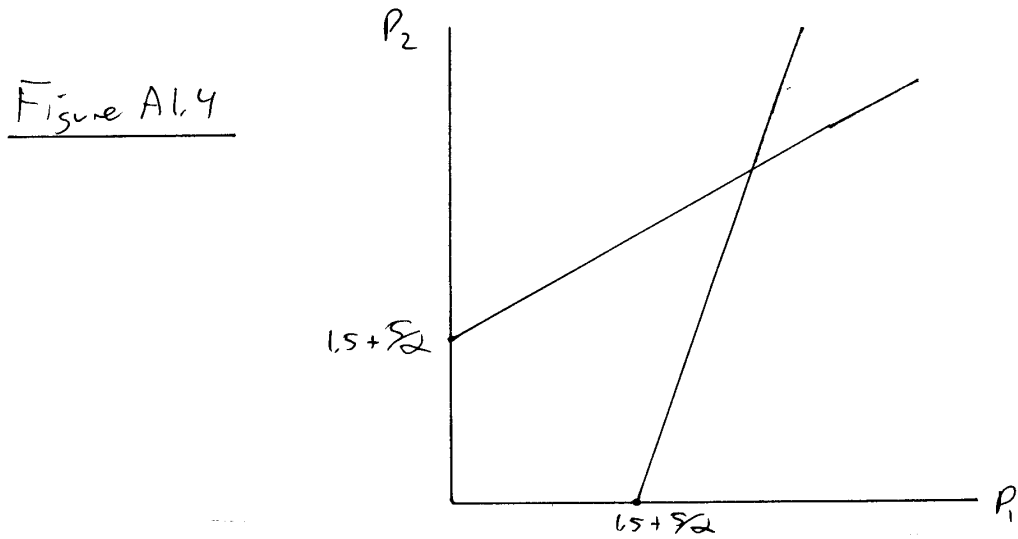

- (13.1b) What is the equilibrium? What is the equilibrium quantity for Firm 1?

Answer. Using the symmetry of the problem, set $p_1 = p_2$ in the reaction function for Firm 1 and solve, to give $p_1^* = p_2^* = \frac{10 + 3\alpha}{2\alpha - \beta}$. Using the demand function for Firm 1, $q_1 = \frac{10\alpha + 3\alpha(\beta - \alpha)}{2\alpha - \beta}$.

- (13.1c) Show how Firm 2's reaction function changes when β increases. What happens to the reaction curves in the diagram?

Answer. The slope of Firm 2's reaction curve is $\frac{\partial p_2}{\partial p_1} = \frac{\beta}{2\alpha}$. The change in this when β changes is $\frac{\partial^2 p_2}{\partial p_1 \partial \beta} = \frac{1}{2\alpha} > 0$. Thus, Firm 2's reaction curve becomes steeper, as shown in Figure A.11.

Figure A.11 How Reaction Curves Change When β Increases

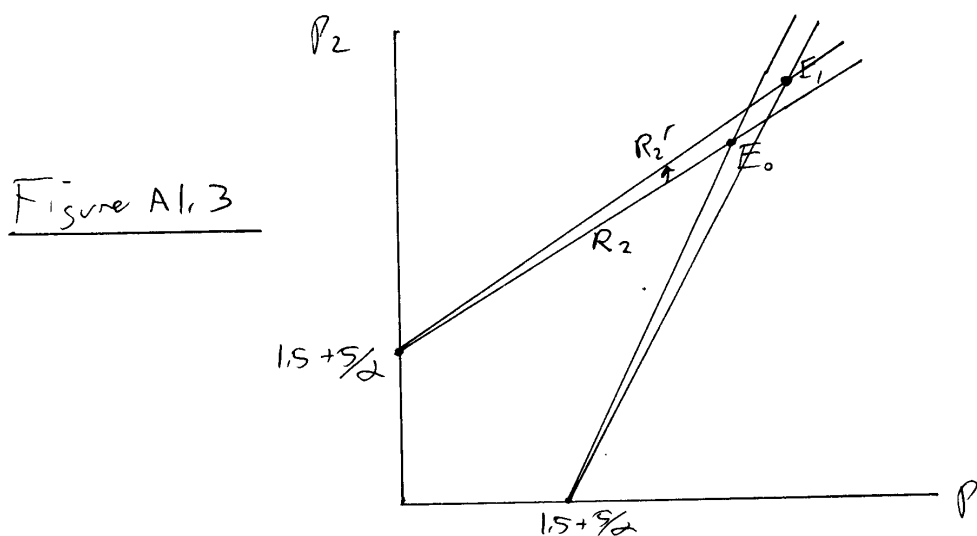

- (13.1d) Suppose that an advertising campaign could increase the value of β by one, and that this would increase the profits of each firm by more than the cost of the campaign. What does this mean? If either firm could pay for this campaign, what game would result between them?

Answer. The meaning of an increase in β is that a firm's quantity demanded becomes more responsive to the other firm's price, if it charges a high price. The meaning is really mixed: partly, the goods become closer substitutes, and partly, total demand for the two goods increases.

If either firm could pay, then a game of "Chicken" results, with pay-offs something like in Table A.14, where the ad campaign costs 1 and yields extra profits of 4 to each firm.

Table A.14 An Advertising “Chicken” Game

		Firm 2	
		<i>Advertise</i>	<i>Do not advertise</i>
Firm 1:	<i>Advertise</i>	3,3	→ 3,4
	<i>Do not advertise</i>	↓ 4,3	← ↑ 0,0

Payoffs to: (Firm 1, Firm 2).

13.3: Differentiated Bertrand. Two firms that produce substitutes have the demand curves

$$q_1 = 1 - \alpha p_1 + \beta(p_2 - p_1) \tag{66}$$

and

$$q_2 = 1 - \alpha p_2 + \beta(p_1 - p_2), \tag{67}$$

where $\alpha > \beta$. Marginal cost is constant at c , where $c < 1/\alpha$. A player’s strategy is his price.

- 13.3a) (What are the equations for the reaction curves $p_1(p_2)$ and $p_2(p_1)$? Draw them.

Answer. Firm 1 solves the problem of maximizing $\pi_1 = (p_1 - c)q_1 = (p_1 - c)(1 - \alpha p_1 + \beta[p_2 - p_1])$ by choice of p_1 . The first order condition is $1 - 2(\alpha + \beta)p_1 + \beta p_2 + (\alpha + \beta)c = 0$, which gives the reaction function $p_1 = \frac{1 + \beta p_2 + (\alpha + \beta)c}{2(\alpha + \beta)}$. For p_2 : $p_2 = \frac{1 + \beta p_1 + (\alpha + \beta)c}{2(\alpha + \beta)}$. Figure A.12 shows the reaction curves. Note that $\beta > 0$, because the goods are substitutes.

Figure A.12 Reaction Curves for the Differentiated Bertrand Game

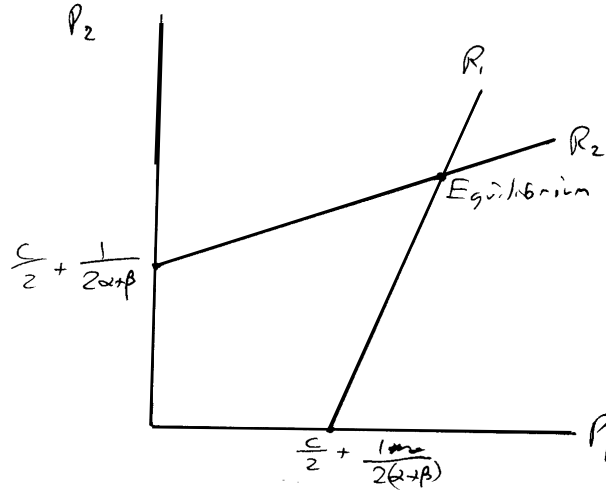

Reaction Curves for the Differentiated Bertrand Game

(13.3b) What is the pure-strategy equilibrium for this game?

Answer. This game is symmetric, so we can guess that $p_1^* = p_2^*$. In that case, using the reaction curves, $p_1^* = p_2^* = \frac{1+(\alpha+\beta)c}{2\alpha+\beta}$.

(13.3c) What happens to prices if α , β , or c increase?

Answer. The response of p^* to an increase in α is:

$$\frac{\partial p^*}{\partial \alpha} = \frac{c}{2\alpha + \beta} - \frac{2[1 + (\alpha + \beta)c]}{(2\alpha + \beta)^2} = \left(\frac{1}{(2\alpha + \beta)^2} \right) (2\alpha c + \beta c - 2 - 2\alpha c - 2\beta c) < 0. \quad (68)$$

The derivative has the same sign as $-\beta c - 2 < 0$, so, since $\beta > 0$, the price falls as α rises. This makes sense— α represents the responsiveness of the quantity demanded to the firm's own price.

The increase in p^* when β increases is:

$$\frac{\partial p^*}{\partial \beta} = \frac{c}{(2\alpha + \beta)} - \frac{1 + (\alpha + \beta)c}{(2\alpha + \beta)^2} = \left(\frac{1}{(2\alpha + \beta)^2} \right) (2\alpha c + \beta c - 1 - \alpha c - \beta c) < 0. \quad (69)$$

The price falls with β , because $c < 1/\alpha$.

The increase in p^* when c increases is:

$$\frac{\partial p^*}{\partial c} = \frac{\alpha + \beta}{2\alpha + \beta} > 0. \quad (70)$$

When the marginal cost rises, so does the price.

- (13.3d) What happens to each firm's price if α increases, but only Firm 2 realizes it (and Firm 2 knows that Firm 1 is uninformed)? Would Firm 2 reveal the change to Firm 1?

Answer. From the equation for the reaction curve of Firm 1, it can be seen that the reaction curve will shift and swivel as in Figure A.13. This is because $\frac{\partial p_2}{\partial p_1} = \frac{\beta}{2(\alpha+\beta)}$, so $\frac{\partial^2 p_2}{\partial p_1 \partial \beta} = -\frac{\beta}{2(\alpha+\beta)^2} < 0$. Firm 2's reaction curve does not change, and it believes that Firm 1's reaction curve has not changed either, so Firm 2 has no reason to change its price. The equilibrium changes from E_0 to E_1 : Firm 1 maintains its price, but Firm 2 reduces its price. Firm 2 would not want to reveal the change to Firm 1, because then Firm 1 would also reduce its price (and Firm 2 would reduce its price still further), and the new equilibrium would be E_2 .

Figure A.13 Changes in the Reaction Curves

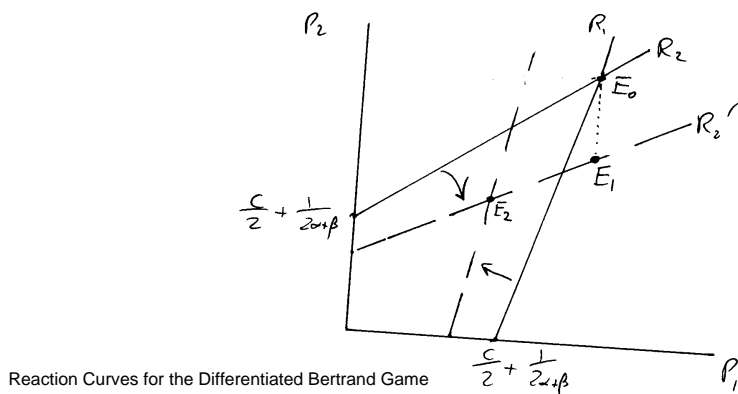

PROBLEMS FOR CHAPTER 14 Entry

14.1: Crazy Predators. (adapted from Gintis [forthcoming], Problem 12.10.)¹³ Apex has a monopoly in the market for widgets, earning profits of m per period, but Brydox has just entered the market. There are two periods and no discounting. Apex can either Prey on Brydox with a low price or accept Duopoly with a high price, resulting in profits to Apex of $-p_a$ or d_a and to Brydox of $-p_b$ or d_b . Brydox must then decide whether to stay in the market for the second period, when Brydox will make the same choices. If, however, Professor Apex, who owns 60 percent of the company's stock, is crazy, he thinks he will earn an amount $p^* > d_a$ from preying on Brydox. Brydox initially assesses the probability that Apex is crazy at θ .

- (14.1a) Show that under the following condition, the equilibrium will be separating, i.e., Apex will behave differently in the first period depending on whether the Professor is crazy or not:

$$-p_a + m \leq 2d \tag{71}$$

Answer.xxx

- (14.1b) Show that under the following condition, the equilibrium will be pooling, i.e., Apex will behave the same in the first period whether the Professor is crazy or not:

$$\theta \leq \frac{p_b}{p_b + d_b} \tag{72}$$

- (14.1c) If neither of the two conditions above applies, the equilibrium is hybrid, i.e., Apex will use a mixed strategy and Brydox may or may not be able to tell whether the Professor is crazy at the end of the first period. Let α be the probability that a sane Apex preys on Brydox in the first period, and let β be the probability that Brydox stays in the market in the second period after observing Apex chose Prey in the first period.

$$\alpha = \frac{(1 - \theta)p_b}{\theta d_b} \tag{73}$$

$$\beta = \frac{-p_a + m - 2d_a}{m - d_a} \tag{74}$$

¹³xxxxxx check hat he didn't get the problem from me, signal jamming.

(14.1d) Is this behavior related to any of the following phenomenon?– Signalling, Signal Jamming, Reputation, Efficiency Wages.

14.3: A Patent Race. See what happens in Patent Race for an Old Market when specific functional forms and parameters are assumed. Set $f(x) = \log(x)$, $g(y) = .5(1 + y/(1 + y))$ if $y \geq 0$, $g(y) = .5(1 + y/(1 - y))$ if $y \leq 0$, $y = 2$, and $z = 1$. Figure out the research spending by each firm for the three cases of (a) $v = 10$, (b) $v = 4$, and (c) $v = 2$.

Answer.xxx